



Pulse Point™ II Series: Vibrating Rod Installation & Operation Manual



Pulse Point™ II Series: Rod Configuration Installation & Operation Manual

CONTENTS

I. HANDLING & STORAGE	1
II. GENERAL SAFETY.....	2
III. PRODUCT DESCRIPTION	3
IV. MECHANICAL INSTALLATION.....	5
V. ELECTRICAL INSTALLATION	7
VI. SET-UP	14
VII. MAINTENANCE	18
VIII. TROUBLESHOOTING	18

SAFETY SYMBOLS



WARNING:

IDENTIFIES CONDITIONS OR PROCEDURES, WHICH IF NOT FOLLOWED, COULD RESULT IN SERIOUS INJURY. RISK OF ELECTRICAL SHOCK.



CAUTION:

IDENTIFIES CONDITIONS OR PROCEDURES, WHICH IF NOT FOLLOWED, COULD RESULT IN SERIOUS DAMAGE OR FAILURE OF THE EQUIPMENT.

Pulse Point II Series: Rod Configuration Installation & Operation Manual

I. HANDLING AND STORAGE

SAVE THESE INSTRUCTIONS

INSPECTION AND HANDLING

Do not dispose of the carton or packing materials.

Each package should be inspected upon receipt for damage that may have occurred due to mishandling during shipping. If the unit is received damaged, notify the carrier or the factory for instructions. Failure to do so may void your warranty. If you have any problems or questions, consult Customer Support at 800-778-9242.

DISPOSAL AND RECYCLING

This product can be recycled by specialized companies and must not be disposed of in a municipal collection site. If you do not have the means to dispose of properly, please contact for return and disposal instructions or options.

STORAGE

If the device is not scheduled for immediate installation following delivery, the following steps should be observed:

1. Following inspection, repackage the unit into its original packaging.
2. Select a clean dry site, free of vibration, shock and impact hazards.
3. If storage will be extended longer than 30 days, the unit must be stored at temperatures between 32° and 158° F (0° to 70° C) in non-condensing atmosphere with humidity less than 85%.



CAUTION: DO NOT STORE A NON-POWERED UNIT OUTDOORS FOR A PROLONGED PERIOD.

II. GENERAL SAFETY



WARNING: ONLY CERTAIN MODELS CAN BE USED IN HAZARDOUS LOCATIONS; SEE NAMEPLATE. THESE MODELS SHALL ONLY BE USED IN APPLICATIONS COVERED BY THE STATED RATINGS OR NON-HAZARDOUS LOCATIONS.

AUTHORIZED PERSONNEL

All instructions described in this document must be performed by authorized and qualified service personnel only. Before installing the unit, please read these instructions and familiarize yourself with the requirements and functions of the device. The required personal protective equipment must always be worn when servicing this device.

USE

The device is solely intended for use as described in this manual. Reliable operation is ensured only if the instrument is used according to the specifications described in this document. For safety and warranty reasons, use of accessory equipment not recommended by the manufacturer or modification of this device is explicitly forbidden. All servicing of this equipment must be performed by qualified service personnel only. This device should be mounted in locations where it will not be subject to tampering by unauthorized personnel.

MISUSE

Improper use or installation of this device may cause the following:

- Personal injury or harm
- Application specific hazards such as vessel overflow
- Damage to the device or system

If any questions or problems arise during installation of this equipment, please contact Product Support at 800-778-9242.

III. PRODUCT DESCRIPTION

FUNCTION

The LP® II Series is an electronic, vibratory level control designed for use in powders and granular solids. A vibrating rod is used to sense the presence of material.

The rod contains two piezoelectric crystal assemblies. The Piezo crystals convert electrical signals to mechanical movement, and vice versa.

When material comes in contact with the rod it will cause a reduction in the level of vibration. If the reduction of the vibration is greater than the set threshold determined by the sensitivity setting the alarm relay will turn ON or OFF depending on the fail-safe settings.

APPLICATIONS

Unlike radio frequency and capacitance technology sensors, the LP II Series devices sense material using a mechanical principle and are therefore not affected by the dielectric constant of the material. These are ideal sensors in plastics, dust, shavings, and low-density powders and food. The rod is more often used in larger size materials such as gravel or pellets.

FEATURES

- Universal input power; AC or DC (see specifications for input ranges)
- No calibration required
- Adjustable time delay
- Selectable fail-safe operation (high or low level)
- Adjustable Sensitivity

TECHNICAL SPECIFICATIONS: ROD CONFIGURATIONS

FUNCTIONAL	
Power Requirements Universal	(± 10%), 120-240 VAC 50/60 Hz or 24-48 VDC
Power Consumption	4 W AC; 4 W DC
Fuse	Slow Blow, 0.5 A 300 V (Not User Serviceable)
Operating Temperature	
Electronics: Ordinary Location	-40° to 158° F (-40° to 70° C)
Electronics: Hazardous Location	-4° to 158° F (-20° to 70° C)
Electronics: Hazardous Location -T	-40° to 158° F (-40° to 70° C)
Process: Standard Temperature	-22° to 203° F (-30° to 95° C)
Process: High Temperature	-22° to 320° F (-30° to 160° C)
Outputs	
Main Relay	8 A DPDT @ 240 VAC or 30 VDC (resistive)
Auxiliary Relay - ADVANCED ONLY	0.46 A SPDT @ 125 VAC or 1 A @ 30 VDC
PERFORMANCE	
Pressure Rating	150 psi (10.5 kg/cm ²) with 3/4" NPT; 50 psi (3.5 kg/cm ²) with 1 1/4" NPT
Time Delay - STANDARD	Field Adjustable; Up to 6 seconds
Time Delay - ADVANCED	Field Adjustable; Up to 150 seconds
Fail Safe	Field Selectable; high/low level
Sensitivity - STANDARD	Minimum 6 lbs/ ft ³ (96 kg/m ³); Field Adjustable
Sensitivity - ADVANCED	Minimum 3 lbs/ft ³ (48 kg/m ³); Field Adjustable
Remote Distance	50 ft. (15 m) Max
PHYSICAL	
Enclosure Material	Powder or Epoxy Coated Aluminum or 304 SS
Process Fitting	NPT 3/4", 1 1/4", 1 1/2" BSP R 1 1/4", 1 1/2" BSP G 1 1/4", 1 1/2"
Rod Material	316 Stainless Steel
Dual Conduit Entry	3/4" NPT or M20 x 1.5
Mounting Plate Material	Mild Steel, 304 Stainless Steel
Extended Pipe Material	316 Stainless Steel
Shipping Weight	Integral, non-extended 10 lb (4.5 kg)
Pollution Degree	2
Installation Category	II
Altitude	6,562 ft (2,000 m)

APPROVALS & RATINGS

UL:

- Ordinary Location Type 4X; IP66 (US and Canada)
- Hazardous Location, Type 4X
 - Explosion Proof, Class I, Div 1, Groups C, D (US Only)
 - Dust Ignition Proof, Class II, Div 1, Groups E, F, G (US and Canada)

CE

- Electromagnetic Compatibility Directive
- Low Voltage Directive

IV. MECHANICAL INSTALLATION



WARNING: HIGH VOLTAGE IS PRESENT. REMOVE POWER FROM THE UNIT BEFORE INSTALLING, REMOVING, OR MAKING ADJUSTMENTS.



WARNING: IN ORDER TO MAINTAIN SAFE OPERATION IN HAZARDOUS LOCATIONS, THE INTEGRITY OF THE ALUMINUM CASTING AND THE ENVIRONMENTAL SEALS MUST BE MAINTAINED. THE USER/INSTALLER MUST AVOID INSTALLATIONS WHERE AGGRESSIVE SUBSTANCES MAY BE PRESENT AND COULD AFFECT THE PERFORMANCE OF THESE MATERIALS. CARE MUST ALSO BE EXERCISED WHEN REMOVING AND REPLACING THE COVER, SO NO MARRING, SCRATCHING OR DAMAGE OCCURS TO THE FLANGES, AND THAT FLANGE SURFACES REMAIN COMPLETELY CLEANED OF DEBRIS.



WARNING: FOR UNITS INSTALLED IN HAZARDOUS LOCATIONS, TO REDUCE THE RISK OF IGNITION OF HAZARDOUS ATMOSPHERES, CONDUIT RUNS MUST HAVE A SEALING FITTING CONNECTION WITHIN 18 IN. OF THE ENCLOSURE.



WARNING: FOR PRODUCTS MARKED AS TYPE 4X, USE TYPE 4X HUB FITTING; FOR IP66 USE IP66 HUB FITTING.

The following precautions should be observed when installing and operating an LP II device:

- The installation and wiring of this product must comply with all national, federal, state, municipal and local codes that apply.
- The LP II Series are precision devices - handle carefully to prevent damage to the rod.
- Do not allow moisture to enter the electronics enclosure. Conduit should slope downward from the LP II housing. Install drip loops (or drain fitting) and seal conduit with silicone rubber product.
- The resonant frequency of the rod is 400 Hz ($\pm 10\%$); locations subject to vibration frequencies greater than 100 Hz should be avoided.



CAUTION: WHETHER MOUNTING DIRECTLY THROUGH A SIDE WALL, OR PIPE EXTENDED AND MOUNTED VERTICALLY THROUGH THE TOP OF A VESSEL, NEVER ATTEMPT TO MOUNT THROUGH A FULL COUPLING.



CAUTION: WHEN MOUNTING UNITS, NEVER ADJUST THE ORIENTATION BY TURNING THE HOUSING. USE A WRENCH FOR PROCESS FITTING UNITS, OTHERWISE A STRAP WRENCH SHOULD BE USED TO TIGHTEN INTO PLACE. ATTEMPTING TO TIGHTEN THE UNIT BY ROTATING THE HOUSING OR ROD MAY DAMAGE THE UNIT AND VOID THE WARRANTY.



CAUTION: THE MAXIMUM ALLOWABLE DOWNWARD FORCE ON THE ROD IS 700 IN. LBS.



CAUTION: PROPER AND SAFE OPERATION REQUIRES THE UNIT TO BE SECURELY MOUNTED TO THE VESSEL AND WRENCH TIGHTENED. THE COVER MUST BE PROPERLY INSTALLED WHEN POWER IS SUPPLIED.

The LP II unit must be located at the position where level indication is desired. The unit may be mounted through the top or side wall of the vessel. To ensure reliable operation, observe the following guidelines when choosing the mounting location.

If using a remote unit, remote turtle cannot be mounted more than 50 feet (15m) away from the probe.

DO NOT mount the unit in an area where the rod can contact the vessel.

The assembly must be horizontal or pointing downward. DO NOT mount the rod pointing upward. If the unit is to be used with powders, it should be installed vertically, or at a downward angle that exceeds the angle of repose to reduce material build-up (see figure 1).

Figure 1. Mounting Orientation

Do not mount the rod directly in the flow of material. If necessary, use a baffle to protect the rod from falling material. The baffle should be placed 6 to 8 inches (15 to 20 cm) above the rod so that material will not become packed between the rod and the baffle (see figure 2).

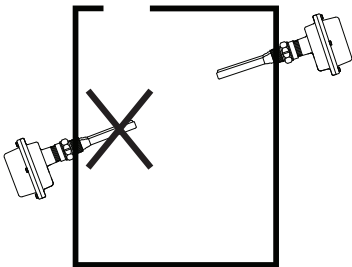
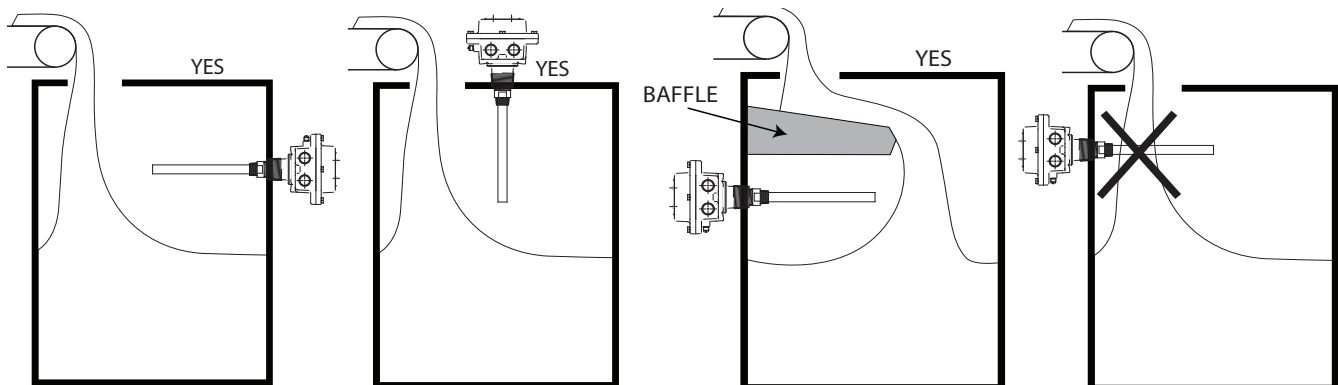

Figure 2. Mounting In Relation To Flow of Material



V. ELECTRICAL INSTALLATION



WARNING: HIGH VOLTAGE IS PRESENT. REMOVE POWER FROM THE UNIT BEFORE INSTALLING, REMOVING, OR MAKING ADJUSTMENTS.



WARNING: FOR UNITS INSTALLED IN HAZARDOUS LOCATIONS, TO REDUCE THE RISK OF IGNITION OF HAZARDOUS ATMOSPHERE, CONDUIT RUNS MUST HAVE A SEALING FITTING CONNECTING WITHIN 18 IN. OF THE ENCLOSURE.



WARNING: FOR PRODUCTS MARKED AS TYPE 4X, USE TYPE 4X HUB FITTING; FOR IP66 USE IP66 HUB FITTING.



CAUTION: IF THE UNIT WAS SUPPLIED WITH A GASKET, AVOID FOLDING, CUTTING OR TEARING THE GASKET. DAMAGING THE GASKET CAN ALLOW MOISTURE TO ENTER THE ENCLOSURE AND DAMAGE THE UNIT.



CAUTION: TO REDUCE THE RISK OF IGNITION IN HAZARDOUS ATMOSPHERES, DISCONNECT THE EQUIPMENT FROM SUPPLY CIRCUIT BEFORE OPENING. KEEP ASSEMBLY TIGHTLY CLOSED WHEN IN OPERATION.

CAUTION: PROPER AND SAFE OPERATION REQUIRES THE UNIT TO BE SECURELY MOUNTED TO THE VESSEL AND WRENCH TIGHTENED. THE COVER MUST BE PROPERLY INSTALLED WHEN POWER IS APPLIED.

GENERAL SAFETY

When using electrical equipment, you should always follow basic safety precautions, including the following:

- The installation and wiring of this product must comply with all national, federal, state, municipal, and local codes that apply.
- Properly ground the enclosure to an adequate earth ground.
- Do not modify any factory wiring. Connections should only be made to the terminals described in this section.
- All connections to the LP II Series models must use conductors with an insulation rating of 300 V minimum, rated for 212° F (105° C), a minimum flammability rating of VW-1, and be of appropriate gauge for the voltage and current required (See Specifications).
- Do not allow moisture to enter the electronics enclosure. Conduit should slope downward from the LP II housing. Install drip loops and seal conduit with silicone rubber product.

DISCONNECT REQUIREMENTS FOR PERMANENTLY INSTALLED EQUIPMENT

A dedicated disconnecting device (circuit breaker) must be provided for the proper installation of the unit. If independent circuits

are used for power input and main relay outputs, individual disconnects are required. Disconnects must meet the following requirements:

- Located in close proximity to the device
- Easily accessible to the operator
- Appropriately marked as the disconnect for the device and associated circuit
- Sized appropriately to the requirements of the protected circuit (See Specifications)

PROTECTIVE EARTH GROUND

To eliminate shock hazards in the unlikely event of an internal insulation breakdown, the unit is provided with an "earth" lead which must be connected to earth ground. In addition, the input power ground lead must be connected to the "protective earth" () terminal provided. Wire sizes must be selected such that it can safely carry the sum total of all circuits' maximum amperage.

CONDUIT CABLE CONNECTION

Two threaded female conduit openings are provided in the housing for input and output wiring. When only one conduit opening is used for installation, the unused opening must be sealed with a suitable type 4X/IP66 plug with pipe sealant in order to maintain approval requirements.

ELECTRICAL CONNECTIONS

Note: The LP II can be operated from 120-240 VAC 50/60 Hz or 24-48 VDC and provides reverse polarity protection in the event of a wiring error.

LP II SERIES INTEGRAL MODEL ONLY

Input Power Connections

1. Refer to Figures 3 or 4 and 5 when connecting input power to the unit.
2. Loosen the housing cover screws and remove cover.



CAUTION: IF THE UNIT WAS SUPPLIED WITH A GASKET AVOID FOLDING, CUTTING, OR TEARING GASKET. DAMAGING THE GASKET CAN ALLOW MOISTURE TO ENTER THE ENCLOSURE AND DAMAGE THE UNIT.

Note: Two threaded female conduit openings are provided in the housing to separate input and output wiring.

3. Pull approximately 4.5" of cable through conduit closest to the grounding bracket and strip as follows:
 - a. Ground – $\frac{3}{8}$ " (9 to 10 mm)
 - b. Power Leads – $\frac{1}{4}$ " (6 to 7 mm)
4. Attach incoming ground lead to grounding bracket as shown in Figure 5.

Note: The LP II incorporates pluggable terminal blocks for ease of connection. If the terminal block is unplugged while making

connections, ensure it is seated properly when reinstalled.

5. Attach power leads to terminal block as shown in Figure 3 or 4. (3.5 in-lb, 0.4 N-m)
6. Check that all wires are held tightly in place by lightly pulling each conductor.

Main Relay Connections

7. Refer to Figures 3 or 4 and 6 when connecting to the main relay.
8. Pull approximately 4.5" (11.43 cm) of cable through conduit and strip $\frac{1}{4}$ " (6 to 7 mm).
9. Attach leads to terminal block as shown in Figure 6. (3.5 in-lb, 0.4 N-m)
10. Check that all wires are held tightly in place by lightly pulling each conductor.

For STANDARD models skip to Step 15; for ADVANCED models continue to Step 11.

Auxiliary Relay Connections - ADVANCED MODEL ONLY

11. Refer to Figures 4 and 7 when connecting to the auxiliary relay.
12. Pull approximately 5.5" (13.97 cm) of cable through conduit and strip $\frac{1}{4}$ " (6 to 7 mm).
13. Attach leads to terminal block as shown in Figure 7. (2.0 in-lb, 0.23 N-m)
14. Check that all wires are held tightly in place by lightly pulling each conductor.
15. Reinstall the gasket, if necessary.
16. Replace cover and tighten screws to 60 in-lb (6.8 N-m) of torque.

LP II SERIES REMOTE MODEL ONLY

Input Power Connections

1. Refer to Figures 8 or 9 and 5 when connecting input power to the unit.
2. Loosen set screw that locks cover in place.
3. Unscrew the housing cover and remove.

Note: Two threaded female conduit openings are provided in the remote housing to separate input and output wiring from the remote rod wiring.

4. Pull approximately 6" (15.24 cm) of cable through conduit closest to grounding bracket and strip as follows:
 - a. Ground – $\frac{3}{8}$ " (9 to 10 mm)
 - b. Power Leads – $\frac{1}{4}$ " (6 to 7 mm)
5. Attach incoming ground lead to grounding bracket as shown in Figure 5.

Note: The LP II incorporates pluggable terminal blocks for ease of connection. If the terminal block is unplugged while making connections, ensure it is seated properly when reinstalled.

6. Attach power leads to terminal block as shown in Figure 8 or 9. (3.5 in-lb, 0.4 N-m)
7. Check that all wires are held tightly in place by lightly pulling each conductor.

Main Relay Connections

8. Refer to Figures 8 or 9 and 6 when connecting to the main relay.
9. Pull approximately 9" (22.86 cm) of cable through conduit and strip 1/4" (6 to 7 mm).
10. Attach leads to terminal block as shown in Figure 6. (3.5 in-lb, 0.4 N-m)
11. Check that all wires are held tightly in place by lightly pulling each conductor.

For STANDARD models, skip to Step 16; for ADVANCED models continue to Step 12.

Auxiliary Relay Connections - ADVANCED MODEL ONLY

12. Refer to Figures 9 and 7 when connecting to the auxiliary relay.
13. Pull approximately 2.5" (6.35 cm) of cable through conduit and strip 1/4" (6 to 7 mm).
14. Attach leads to terminal block as shown in Figure 7. (2.0 in-lb, 0.23 N-m)
15. Check that all wires are held tightly in place by lightly pulling each conductor.

Remote Rod Connections

16. Refer to Figure 10 when connecting the remote rod.
17. Pull approximately 2.5" (6.35 cm) of cable through conduit and strip 3/16" (4 to 5 mm).
18. Connect factory supplied cable to terminal board as shown in Figure 10.
19. Check that all wires are held tightly in place by lightly pulling each conductor.
20. Replace cover and tighten set screw to lock cover in place.
21. Loosen the remote housing cover screws and remove cover.
22. Pull approximately 4" (10.16 cm) of cable through conduit and strip 3/16" (4 to 5 mm).

Figure 3. LP II Integral Enclosure with Cover Removed - STANDARD

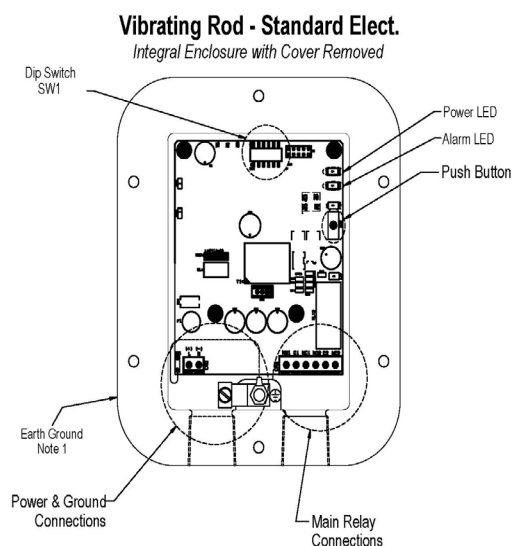

Note:

- 1. For safety, properly ground the enclosure to an adequate earth ground.**

23. Connect factory supplied cable to terminal board as shown in Figure 10.
24. Check that all wires are held tightly in place by lightly pulling each conductor.
25. Reinstall the gasket, if necessary.
26. Replace cover and tighten screws to 60 in-lb (6.8 N-m) of torque.

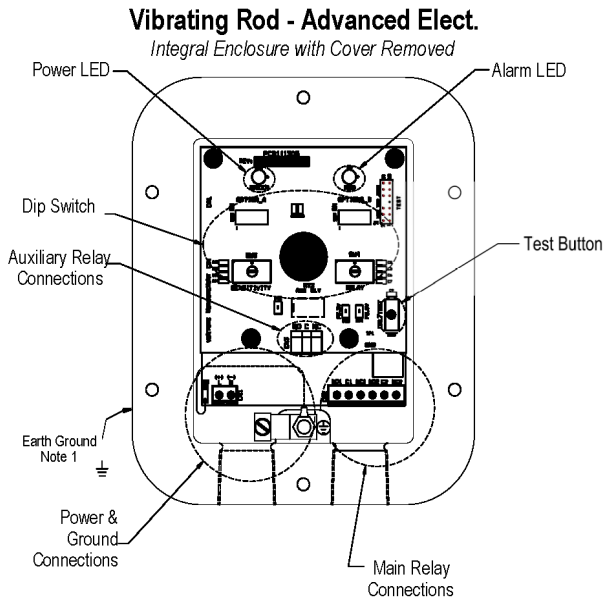

CAUTION: IF THE UNIT WAS SUPPLIED WITH A GASKET AVOID FOLDING, CUTTING, OR TEARING GASKET. DAMAGING THE GASKET CAN ALLOW MOISTURE TO ENTER THE ENCLOSURE AND DAMAGE THE UNIT.

Figure 4. LP II Integral Enclosure with Cover Removed - ADVANCED

Figure 5. Power and Ground Connections

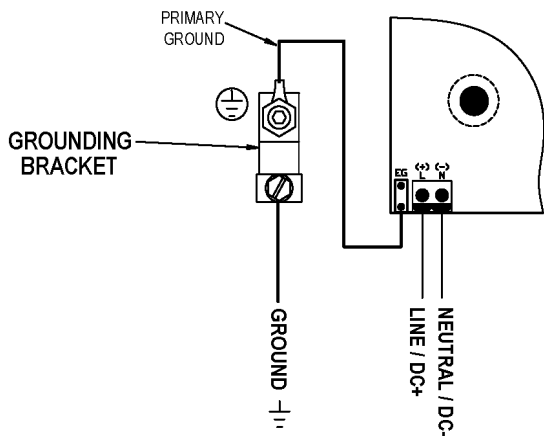

Figure 6. Main Relay Connections

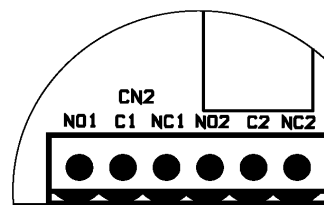
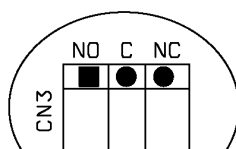

Figure 7. Auxiliary Relay Connections - ADVANCED ONLY



Note:

1. For safety, properly ground the enclosure to an adequate earth ground.

Figure 8. LP II Remote Enclosure with Cover Removed - STANDARD

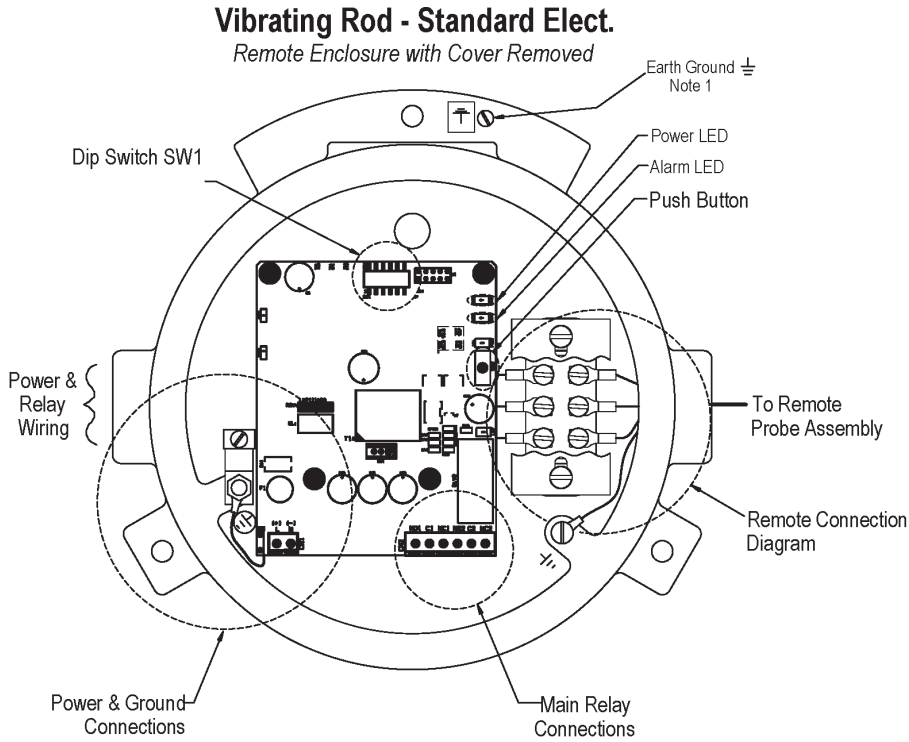
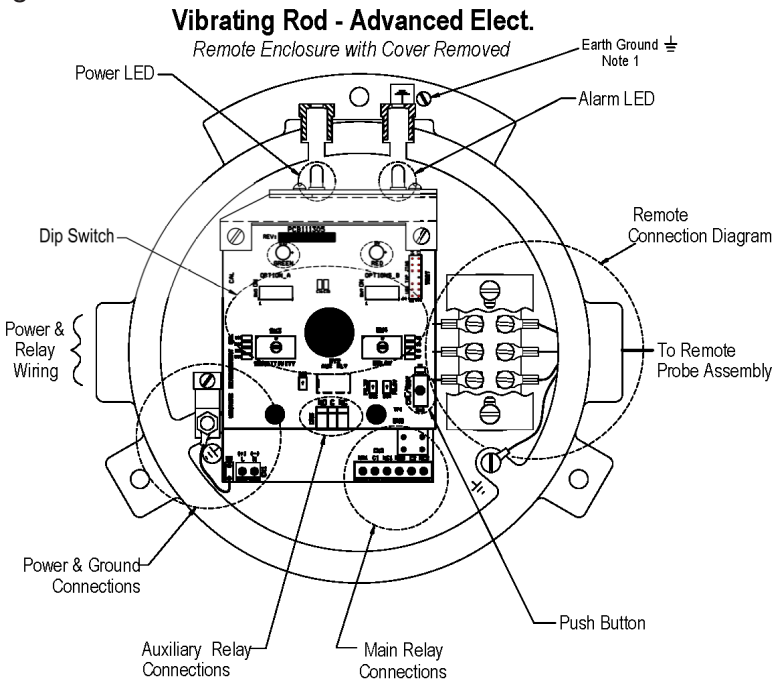

Figure 9. LP II Remote Enclosure with Cover Removed - ADVANCED



Note:

1. For safety, properly ground the enclosure to an adequate earth ground.

Figure 10. LP II Remote Connection Diagram

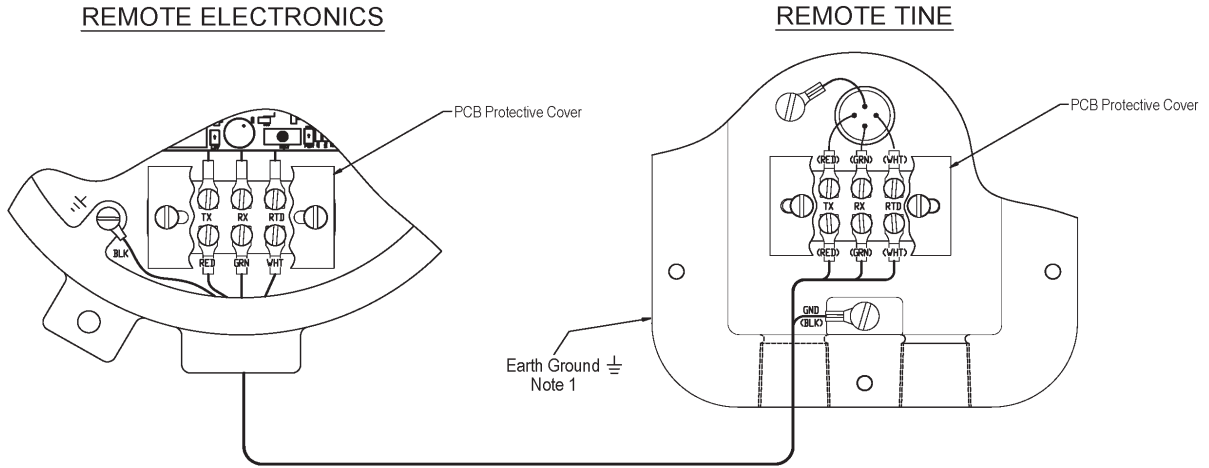

WIRING COLORS
For both Standard and Hi-temp Cable Assemblies
 RTD= WHITE
 REC.= GREEN
 TRAN.= RED
 GND.= BLACK

Notes:
 1) For Safety, Properly Ground the Enclosure to an Adequate Earth Ground.

VI. SET-UP



WARNING: HIGH VOLTAGE PRESENT.
REMOVE POWER FROM THE UNIT BEFORE INSTALLING, REMOVING, OR MAKING ADJUSTMENTS.



CAUTION: TO REDUCE THE RISK OF IGNITION IN HAZARDOUS ATMOSPHERES, DISCONNECT THE EQUIPMENT FROM SUPPLY CIRCUIT BEFORE OPENING. KEEP ASSEMBLY TIGHTLY CLOSED WHEN IN OPERATION.

OPERATION

The LP II does not require calibration. When power is applied to the unit, the rod will begin vibrating (if the rod is not impeded by contact with material or some other object). The green Power LED will be illuminated whenever power is applied to the unit. The status of the red Alarm LED is determined by the selected fail-safe mode and whether or not the rod is vibrating. Refer to Fail-Safe Selection section.

PRODUCT OVERVIEW - STANDARD MODEL

Figures 3 and 8 show the electronics of the integral and remote versions of the LP II respectively. The figures show the location of the electrical connections, dip switch SW1, and the Power and Alarm LEDs. This section will discuss configuration for optimum performance in a given application. The settings are controlled by SW1 as shown in Figure 11.

Figure 11: Option Selection Switch, Standard

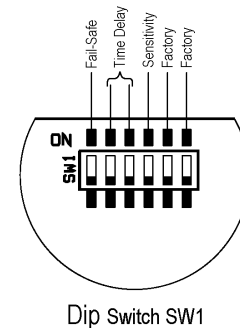

PRODUCT OVERVIEW - ADVANCED MODEL

Figures 4 and 9 show the electronics of the integral and remote versions of the LP II respectively. The figures show the location of the electrical connections, dip switch SW5, two rotary switches SW3 and 4, and the Power and Alarm LEDs. This section will discuss configuration for optimum performance in a given application. The settings are controlled by SW3 through 5 as shown in Figure 12.

Figure 12: Option Selection Switch, Advanced

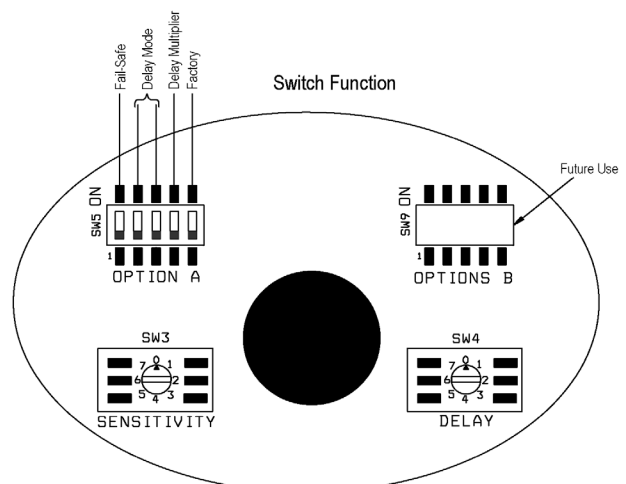

FAIL-SAFE SELECTION

The LP II is factory set for high level fail-safe operation. The Fail-Safe is controlled by SW1, position 1 on Standard units; SW5, position 1 for Advanced units. Refer to Figure 13 to determine the Fail-Safe mode that suits your application.

Figure 13. Fail-Safe Operation

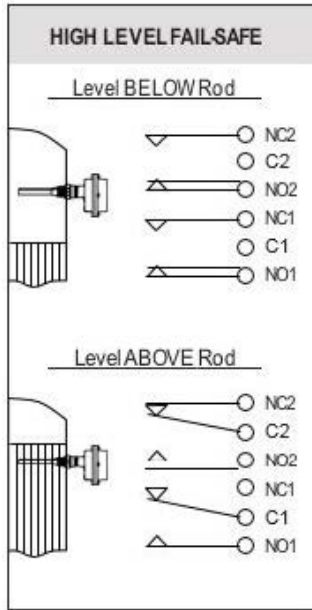

HIGH LEVEL FAIL-SAFE OPERATION (DEFAULT)

DIP Switch Settings

- STANDARD: SW1-1 is OFF
- ADVANCED: SW5-1 is OFF

Alarm State (material above the rod)

- Main Relay is de-energized
 - Relay NC contacts are closed
 - Relay NO contacts are open
- Alarm LED is ON

Non-Alarm State (material below the rod)

- Main Relay is energized
 - Relay NC contacts are open
 - Relay NO contacts are closed
- Alarm LED is OFF

Note: If the electrical power fails, the main relay turns OFF, giving the same indication as if material is above the rod.

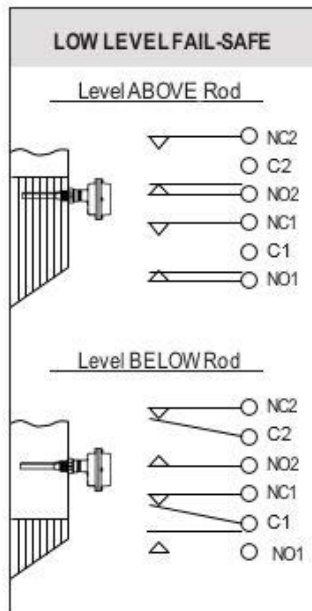

LOW LEVEL FAIL-SAFE OPERATION

DIP Switch Settings

- STANDARD: SW1-1 is ON
- ADVANCED: SW5-1 is ON

Alarm State (material below the rod)

- Main Relay is de-energized
 - Relay NC contacts are closed
 - Relay NO contacts are open
- Alarm LED is ON

Non-Alarm State (material above the rod)

- Main Relay is energized
 - Relay NC contacts are open
 - Relay NO contacts are closed
- Alarm LED is OFF

Note: If the electrical power fails, the main relay turns OFF, giving the same indication as if material is below the rod.

TIME DELAY SETTINGS - STANDARD MODEL

This setting will delay the time between when the LP II senses material and the main relay changes state. **The delay is only in this direction, regardless of fail-safe setting.** There is no added delay when the material leaves the rod. Duration of the delay is determined by SW1 positions 2, and 3 as described in the table below. The LP II is factory set for no delay.

SW1 Position 2	SW1 Position 3	Delay (seconds)
OFF	OFF	NO DELAY
OFF	ON	1
ON	OFF	3
ON	ON	6

TIME DELAY SETTINGS - ADVANCED MODEL

The time between when the LP II senses material, or its absence, and the output relay changes state is field programmable using SW5 Positions 2 and 3. The delay can be for when the product touches the rod or when the product leaves the rod or both regardless of the fail-safe setting. The delay duration is determined by SW4 and SW5 position, which determines if a multiplier is applied.

SW5 Position 2	Delay Mode
ON	The selected delay by the SW4 is applied when material touches the rod
OFF	There is no delay when material touches the rod
SW5 Position 3	Delay Mode
ON	The selected delay by the SW4 is applied when material leaves the rod
OFF	There is no delay when material leaves the rod

SW4	SW5 Position 4	Delay (seconds)
0	OFF	NO DELAY
1	OFF	1
2	OFF	3
3	OFF	4
4	OFF	6
5	OFF	9
6	OFF	18
7	OFF	30
0	ON	0
1	ON	5
2	ON	15
3	ON	20
4	ON	30
5	ON	45
6	ON	90
7	ON	150

SENSITIVITY SETTINGS - STANDARD MODEL

There are two (2) different sensitivity ranges on the LP II that can be selected using SW1 Position 4. The unit is factory set for the lowest sensitivity. The table below is for illustration purposes, of a vertically mounted unit only, and results will vary depending on material properties and conditions.

SW1 Position 4	Sensitivity	Bulk Density (lbs/ft ³)
OFF	High	6
ON	Low	≥ 9

SENSITIVITY SETTINGS - ADVANCED MODEL

The LP II provides three (3) levels of sensitivity which are selected using SW3 as shown in the table below. The unit is factory set for the lowest sensitivity. The table below is for illustration purposes, of a vertically mounted unit only, and results will vary depending on material properties and conditions.

SW3	Sensitivity	Bulk Density (lbs/ft ³)
0	High	3
1	Medium	6
2-7	Low	≥ 9

TEST - ADVANCED MODEL

The LP II provides a means for self-test using the magnetic FOB provided with the unit. When the unit is not in material (rod vibrating) place and hold the FOB over the "TEST" label on the cover. If the unit is functioning properly, the alarm LED and main relay will change the state as shown below. When the test is completed and results verified, simply move the FOB away from the unit.

HIGH FAIL-SAFE:

- Main relay de-energizes
- Red ALARM LED is on

LOW FAIL-SAFE

- Main relay energizes
- Red ALARM LED is off

Figure 14: Magnetic FOB

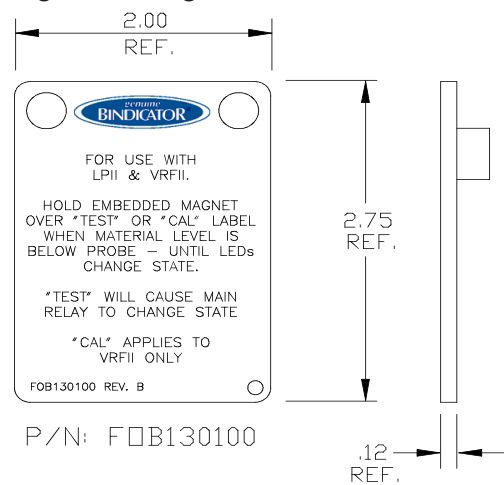

VII. MAINTENANCE



WARNING: TO AVOID IGNITION HAZARD DUE TO ELECTROSTATIC DISCHARGE, CLEAN ONLY WITH A DAMP CLOTH.



WARNING: IN ORDER TO MAINTAIN SAFE OPERATION IN HAZARDOUS LOCATIONS, THE INTEGRITY OF THE ALUMINUM CASTING AND THE ENVIRONMENTAL SEALS MUST BE MAINTAINED. THE USER/INSTALLER MUST AVOID INSTALLATIONS WHERE AGGRESSIVE SUBSTANCES MAY BE PRESENT AND COULD AFFECT THE PERFORMANCE OF THESE MATERIALS. CARE MUST ALSO BE EXERCISED WHEN REMOVING AND REPLACING THE COVER, SO NO MARRING, SCRATCHING OR DAMAGE OCCURS TO THE FLANGES, AND THAT THE FLANGE SURFACES REMAIN COMPLETELY CLEANED OF DEBRIS.



CAUTION: IF THE UNIT WAS SUPPLIED WITH A GASKET, AVOID FOLDING, CUTTING OR TEARING THE GASKET. DAMAGING THE GASKET CAN ALLOW MOISTURE TO ENTER THE ENCLOSURE AND DAMAGE THE UNIT.

PREVENTATIVE MAINTENANCE

No scheduled preventative maintenance is required for the LP II Series units when properly applied and installed correctly. There is no cleaning required for the unit before or during installation.

If the cover is removed after the unit has been in service, it is recommended to replace the gasket to prevent the ingress of water or dust. At a minimum the gasket should be inspected for folds, cracks, and tears.

VIII. TROUBLESHOOTING



CAUTION: PROPER AND SAFE OPERATION REQUIRES THE UNIT TO BE SECURELY MOUNTED TO THE VESSEL AND WRENCH TIGHTENED. THE COVER MUST BE PROPERLY INSTALLED WHEN POWER IS APPLIED.

DIAGNOSTICS

The new LP II single rod has extensive built-in diagnostic routines. If any part of the electronics malfunctions, the unit will detect the problem and indicate it by flashing the GREEN LED. The unique codes are listed in the table below.

CODE	CONDITION	RELAYS
1	No or low excitation to the rod	Aux. Relay: De-energized Alarm Relay: De-energized
2	No return signal from the piezo crystal	Aux. Relay: De-energized Alarm Relay: De-energized
3	Ambient temperature greater than 75°C or less than -40°C	Aux. Relay: De-energized
4	Probe RTD failure	Aux. Relay: De-energized Alarm Relay: De-energized
5	Process Temperature	
	< -30°C	Aux. Relay: De-energized
	< -35°C	Alarm Relay: De-energized
	Standard Temp: >95°C	Aux. Relay: De-energized
	Standard Temp: >100°C	Alarm Relay: De-energized
	High Temp: >160°C	Aux. Relay: De-energized
	High Temp: >165°C	Alarm Relay: De-energized
6	Factory Use Only	Factory Use Only

	SYMPTOM	POSSIBLE CAUSE	SOLUTION
The unit is not responsive	Main relay not Functioning and Power LED is not illuminated	No power, Blown fuse	Apply proper AC/DC voltage to the board and recheck the unit. If power is present and Power LED is not illuminated, then the main fuse is blown. Replace electronics.
	Main relay is functioning and Power LED is illuminated	Electronic failure, or main relay contacts are fused	Replace electronics.
Unit not as sensitive as expected			Ensure the cover is properly torqued and unit is installed wrench tight.



150 Venture Boulevard
Spartanburg, SC 29306
Tel: (800) 778-9242
Fax: (864) 574-8063
sales@bindicator.com
www.bindicator.com



ANDERSON-NEGELE

2025 All rights reserved.
All data subject to change without notice.

LVP180914 Rev. E