

**Dimensions**  
**VRF-2000 Cable Series**

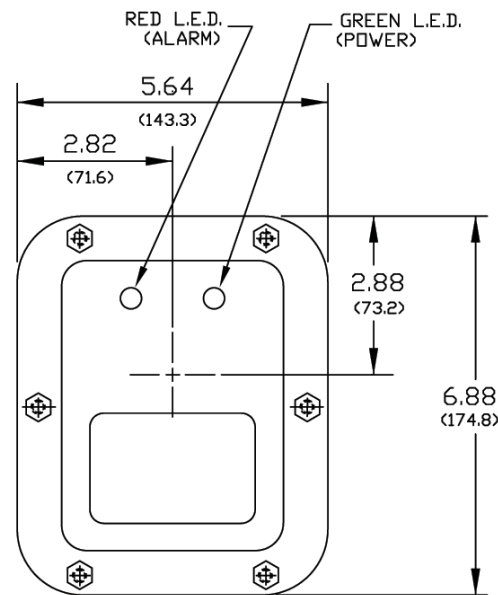

H	11.50 (292.1)	16.25 (412.8)	8.12 (206.2)
G	7.00 (178)	11.75 (298.5)	3.63 (92.2)
F	4.50 (114.5)	10.00 (254)	3.25 (82.6)
E	3.38 (86)	8.50 (216)	2.75 (69.9)
D	10.50 (266.7)	15.25 (387.4)	7.12 (180.8)
C	6.00 (152.5)	10.75 (273)	2.63 (66.8)
B	3.50 (89)	9.00 (228.5)	2.25 (57.2)
A	2.38 (60.5)	7.50 (190.5)	1.75 (44.5)
APPROX DIM'S	STD. & FOODGRADE	H.D.	STUB

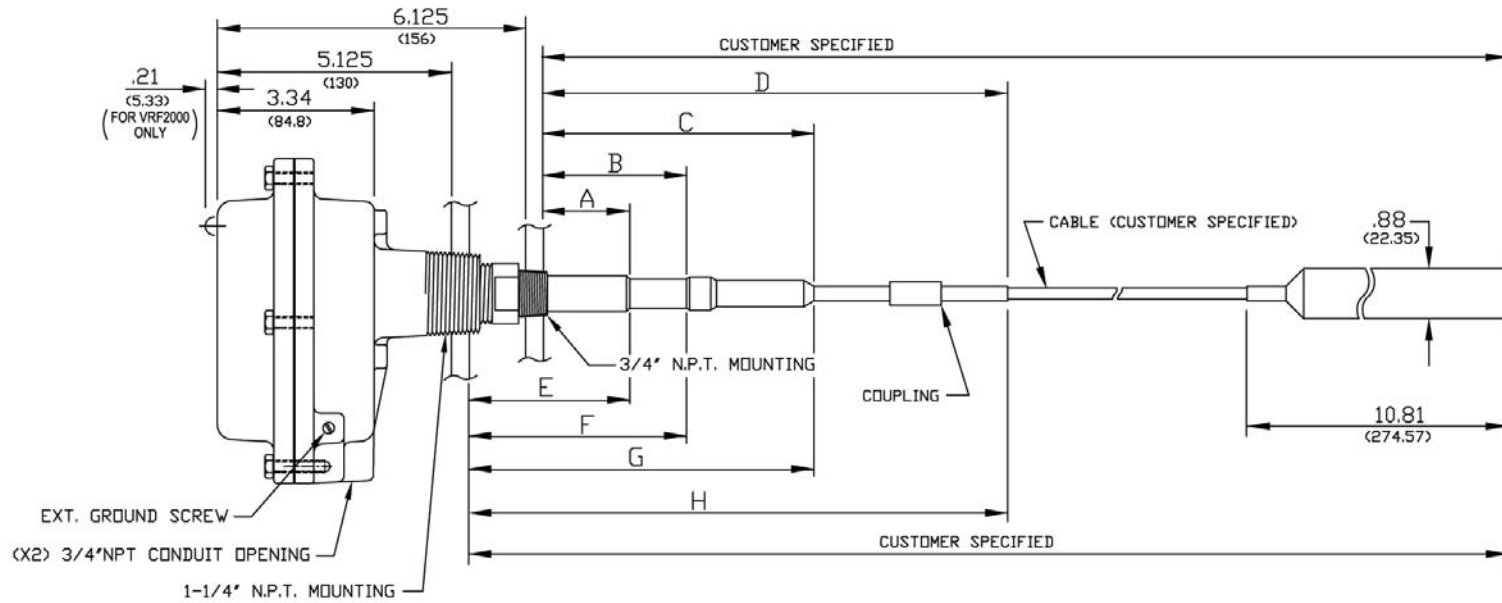

**VRF-2000 Integral Series**

- EZ-Cal® II
- External CAL and alarm lights
- Calibration indication output relay
- External test in place
- Dual conduit housing



**VRF-2000 Cable Series**

- EZ-Cal® II
- External CAL and alarm lights
- Calibration indication output relay
- External test in place
- Dual conduit housing

**Features and Benefits**

**Opti-Sense™**  
Uses variable radio frequency (VRF™) technology to determine the optimal operating frequency for greatest sensitivity and stability

**Wide Variety of Probe Options**  
Unequaled application versatility

**Test In Place**  
Test by using a magnetic fob without removing the cover

**Pro-Guard™**  
Probe design ignores material build-up on probe

**EZ-Cal® II**  
No initial manual calibration required

**Explosion Proof & Stainless Steel Enclosures Available**  
Provides more options for a wide range of applications

**Calibration Status and Alarm Lights**  
Green LED indicates calibration status; red LED indicates alarm status

Surpassing the sensitivity of RF technology, VRF™ provides superior level detection. The VRF™ series uses Variable Radio Frequency to detect the presence or absence of material in a vessel by compensating for the load of the probe, as well as the load induced by vessel environment, and automatically determining the optimal operating frequency for the greatest sensitivity and stability. At initial start-up the sensor detects the characteristics of air (no load) and calibrates to it. If installed in material, when the load is reduced (material leaves probe), the VRF™ senses this change and automatically recalibrates to its new condition without the need of an operator or technician.

Bindicator® manufactures an array of VRF™ probes, each tailored for specific applications. When combined with our large selection of probes, we have a VRF™ sensor for virtually every application. Please consult one of our representatives or call the factory for application assistance.

**How to Order**  
**VRF-2000 Integral Series**

VRF2-

**Assembly Configuration**

- A = 3/4" S.S. & 1 1/4" Aluminum & Flush Probes
- B = Pipe Ext. Probe, S.S. Coupling & Connection
- C = Pipe Ext. Probe, Plated Coupling & Aluminum Connection
- S = Sanitary Connection 1" or 1 1/2" Tri-clamp Size (See Note 1)
- H = 3/4" Hastelloy C (For Teflon® Probes Only)

**Electronics Version**

1 = Standard

**Enclosure Type**

- G = General Purpose NEMA 4X
- S = Stainless Steel Type 304 NEMA 4X

**Probe Type**

- 0 = Standard Ryton®
- 1 = Standard Kynar® Coated (Max. Length 60" or 1524mm)
- 2 = Food Grade Polysulfone
- 4 = Stub Polysulfone
- 5 = Heavy Duty Ryton®
- 6 = Heavy Duty Kynar® Coated
- 7 = Dome Flush (Use "A" Configuration Only) (Specify Thickness - See Note 2)
- 8 = Flush (Use "A" Configuration Only)
- A = Armored Food Grade (Use "A" Configuration Only)
- J = Jumbo (Use "A Configuration Only) (Enclosure Type G or D Only)
- T = Teflon® Jacketed Standard
- U = Teflon® Jacketed Heavy Duty

**Voltage**

- A = AC 85-265 VAC
- D = DC 9-36 VDC

**VRF-2000 Series**

**Note 1:** For 3A Sanitary Certification add "3A" at end of the model code. Configuration "S" must be used and either "Type 2" Food Grade probe or "Type 4" Stub probe.

**Note 2:** Thickness of probe must be specified: 3/8", 1/2", 5/8" or 3/4" wall thickness.



150 Venture Boulevard · Spartanburg, SC 29306  
Tel: (800) 778-9242 · (864) 574-8060  
Fax: (864) 574-8063 E-mail: sales@bindicator.com  
www.bindicator.com

Teflon® is a registered trademark of E.I. Du Pont  
Ryton® is a registered trademark of Chevron Phillips Chemical  
Kynar® is a registered trademark of Arkema, Inc.  
2008 All rights reserved.  
All data subject to change without notice.



## How to Order VRF-2000 Cable Series

**VRF2C**

				<b>Cable Probe Material</b>	
				S = Stainless Steel	
				N = Nylon	
				T = Teflon®	
				<b>Cable Probe Length</b>	
				___ = Specify Insertion Length of Cable Probe Assembly in Inches (See Note 1)	
				<b>Assembly Configuration</b>	
				A = 3/4" S.S. & 1 1/4" Aluminum & Flush Probes	
				S = Sanitary Connection 1" or 1 1/2" Tri-clamp size	
				<b>Electronics Version</b>	
				1 = Standard	
				<b>Enclosure Type</b>	
				G = General Purpose NEMA 4X	
				<b>Probe Type</b>	
				0 = Standard Ryton®	
				2 = Food Grade Polysulfone	
				4 = Stub Polysulfone	
				5 = Heavy Duty Ryton®	
				<b>Voltage</b>	
				A = AC 85-265 VAC	
				D = DC 9-36 VDC	

**VRF-2000 Cable Probe Series**

**Note 1:** Maximum length 45 feet (13.71m) or 540 inches (13716mm).

The VRF™ Cable Series should be used when tank mid or low-level monitoring is desired and the unit must be mounted from the top of the tank. The Cable Series provides the same features and reliability of the standard probe series, however, with a bendable cable, the unit can be conveniently mounted in enclosed environments.

## Electrical Specifications for Integral and Cable Series

- Universal Input Power: 85 VAC - 265 VAC  
DC input power: 9 VDC - 36 VDC
- Power: 5 Watts
- Output Relay: DPDT 6 amps @ 240 VAC, 6 amps @ 30 VDC, Minimum load 12V/100mA
- Temperature Range: -40° F to 158° F (-40° C to 70° C)
- Sensitivity: Rotary-switch selectable for 0.5pF, 1pF, 2pF, 3pF, 5pF, 8pF, 10pF, or 15pF
- Time Delay: Rotary-switch selectable for 200 milliseconds, 1, 2, 5, 10, 20, 30, or 60
- Time Delay Mode: Time delay for activating/deactivating the alarm or both
- Fail Safe: High-Low level failsafe dip-switch
- Calibration: Push-button, intelligent recalibration, external magnetic fob
- Approvals: FM and CSA listed for non-hazardous enclosure types NEMA 4X

## Dimensions VRF-2000 Integral Series

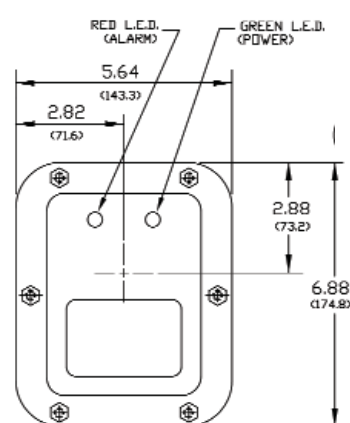
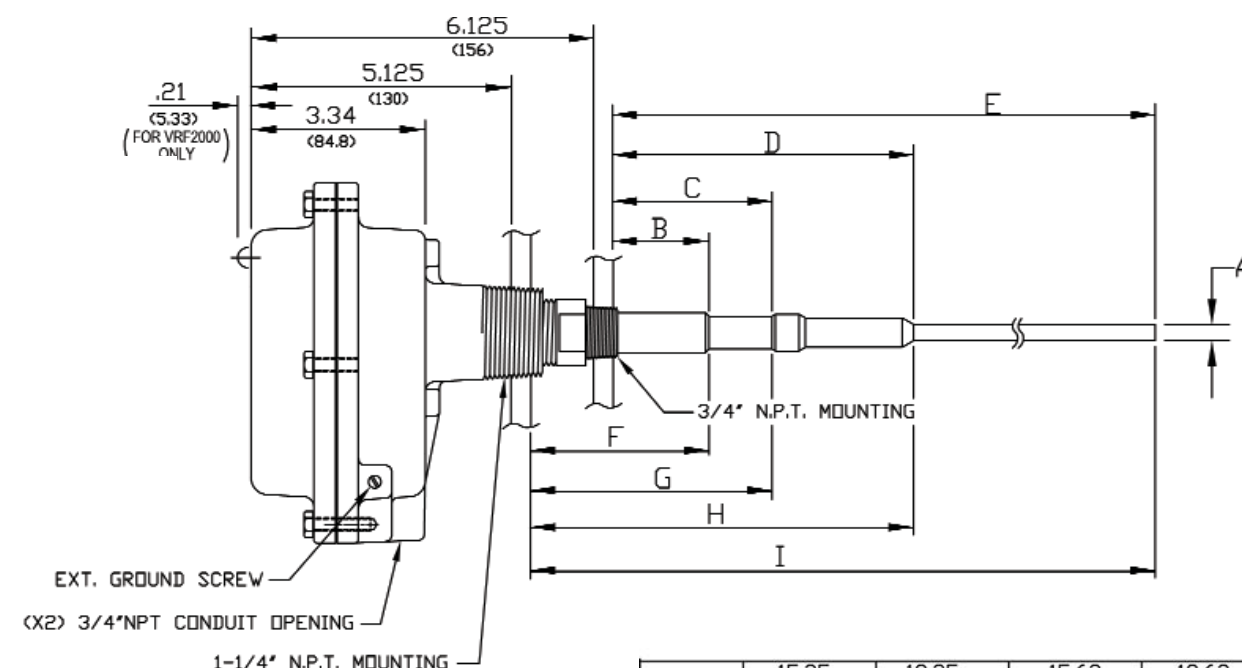

I	15.25 (387.5)	19.25 (489)	15.62 (396.7)	19.62 (498.35)	15.25 (387.35)
H	7.00 (178)	11.75 (298.5)	7.00 (178)	11.75 (298.5)	3.63 (92.2)
G	4.50 (115)	10.00 (254)	4.50 (115)	10.00 (254)	3.25 (82.55)
F	3.38 (86)	8.5 (216)	3.38 (86)	8.5 (216)	2.75 (69.85)
E	14.25 (362)	18.25 (463.5)	14.62 (371.4)	18.62 (472.95)	14.25 (362)
D	6.00 (152.5)	10.75 (273)	6.00 (152.5)	10.75 (273)	2.63 (66.8)
C	3.50 (89)	9.00 (228.5)	3.50 (89)	9.00 (228.5)	2.25 (57.2)
B	2.38 (60.5)	7.50 (190.5)	2.38 (60.5)	7.50 (190.5)	1.75 (44.5)
A	.31 DIA. (8)	.38 DIA. (9.5)	.31 DIA. (8)	.38 DIA. (9.5)	.31 DIA. (8)
APPROX DIM'S	STD. & FOODGRADE	H.D.	STD. KYNAR COATED	H.D. KYNAR COATED	STUB