

RADAR TRACKER®
INSTALLATION & OPERATION MANUAL

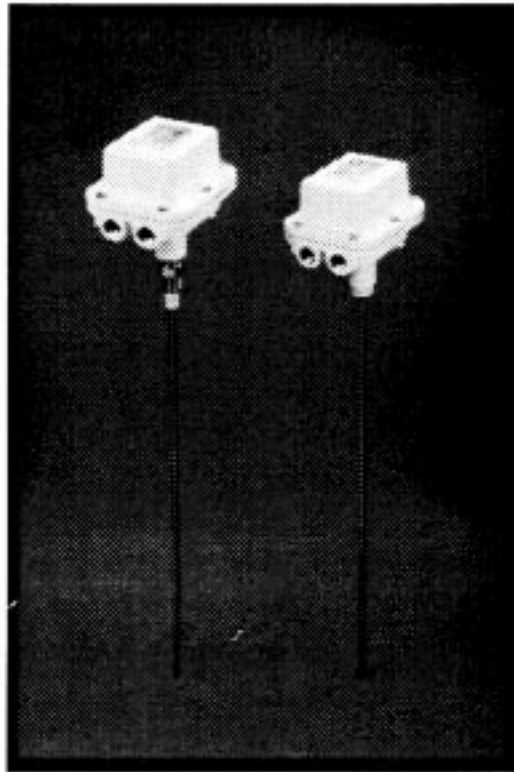

BINDICATOR
150 Venture Boulevard
Spartanburg, SC 29306
Phone: (864) 574-8960, Fax: (864) 578-7308
Customer Service: (800) 778-9242
Internet: <http://www.bindicator.com>
email: sales@bindicator.com

TABLE OF CONTENTS

<u>Section</u>	<u>Description</u>	<u>Page</u>
1.0	INTRODUCTION	3
2.0	OPERATING THEORY	3
3.0	SPECIFICATIONS	3
4.0	MODEL SELECTION	5
5.0	PROGRAMMING DESCRIPTIONS	6
5.1	CALIBRATION	7
5.2	PROGRAMMING MATRIX	8
5.3	PROGRAMMING CONCERNS	9
6.0	APPLICATION ERRORS	10
7.0	TROUBLESHOOTING	10
8.0	REPLACEMENT PARTS	11
9.0	FACTORY ASSISTANCE	12
10.0	WARRANTY & PARTS	12
11.0	DRAWINGS	13
12.0	GENERAL TERMS & CONDITIONS OF SALE	22

1.0 INTRODUCTION

The Radar Tracker® is a line powered level transmitter that produces a 4-20 mA output in addition to 2 control relays. As an option, this transmitter is available with 4 control relays and no current output. This device utilizes the recently developed MIR (micropower impulse radar) technology.

2.0 OPERATING THEORY

This unit operates in the high frequency (microwave) domain. The unit uses the vessel's metal tank top as a launch plate or antenna to send a high frequency (1.8 GHz) signal down the rod or probe. The rod or probe acts as a guide for the high frequency signal. The signal is a wave approximately 3 inches in diameter. The signal travels down the rod at approximately the speed of light (186,282 miles/sec) and is reflected back by the product within the tank. The time it takes for the signal to return is measured. By knowing the velocity, and now knowing the time, we can calculate distance (where distance = velocity x time).

3.0 SPECIFICATIONS

Enclosure: NEMA 4, 4X, 5 aluminum w/ polyester powder coating.
Optional NEMA 4X 304 S.S. enclosure (Integral units only).
NEMA 7, 9 is pending.

Process Connection: ¾" NPT S.S. or 1 ¼" NPT Aluminum

Mounting: a metallic flange or metallic tank top is required for proper operation

Conduit Entry: dual ¾" NPT

Power Input (factory set): 120 VAC, 240 VAC, 100 VAC, or
24 VDC (4 wire) pending

Output:

Option #1: 4-20 mA into 500 ohms & (2) 10A SPDT relays

Option #2: (4) 10A SPDT relays, no 4-20 mA output

Resolution: 1/16" (0.063 inch) or 1.59 mm

Linearity: ±0.1% of maximized span or 0.396 inch

Repeatability: ±0.1% of span

Settling Time: ≤ 2 seconds

Current Loop and Relay Setup: uses STEP and ENTER pushbuttons in conjunction with an onboard 4 character alphanumeric LED display

Minimum Insertion: 0.5 foot or 6 inches (includes 3" deadband)

Maximum Insertion: 33 feet or 396 inches (10.2 m)

Sensing Element: 3/8" DIA, 316 S.S., rigid rod (12 feet max.)
(for Standard 3/4" NPT version)

or

1/2" DIA, 316 S.S., rigid rod (12 feet max.)
(for Heavy Duty 1 1/4" NPT version)

or

3/16" DIA S.S. cable/weight (33 feet max.)
(for Standard and Heavy Duty version)

or

2" sanitary connector (12' max., single rod only)
(other sanitary sizes available upon request)

Operating Temperature: -40° F to 165° F (consult factory >140° F)

Pressure: 1000 psi @ 250° F maximum

Area Classification: General Purpose - pending FM/CSA approval
Explosionproof - pending FM/CSA approval

4.0 MODEL SELECTION

LCR - _ - _ - _ - _ - _ - (.0) - _ - 10

10 Design Level (Assigned by Factory)
10

Modification Code (Assigned by Factory)
A No modification (standard version)
B With 6" lagging for high temperature (for internal bin temperatures above 200°F)

(xxx.0) Probe Length
Insertion length of probe in inches

Probe
A 3/8" DIA, 316 S.S. rigid rod (max. 12 ft) (3.7 m) for "A" & "S" mounting only (See Note 4)
B 1/2" DIA, 316 S.S. rigid rod (max. 12 ft) (4.3 m) for "B" mounting only (See Note 4)
C 3/16" DIA, 316 S.S. cable/weight (max. 33 ft) (10.2 m) for "A" "B" "H" mountings (See Note 5)

Mounting
A 3/4" NPT S.S. (standard version, 1000 psi max. @ 250F)
B 1 1/4" NPT Aluminum (heavy duty version, atmospheric pressure only)
S2 Sanitary (2") for type "A" probe only (atmospheric pressure only)

Voltage
1 120 VAC (± 10%, 50/60 Hz)
2 240 VAC (± 10%, 50/60 Hz)
3 24 VDC (4 wire, ± 10%) (pending)
7 100 VAC (± 10%, 50/60 Hz)

Enclosure Rating
G General Purpose NEMA 4, 4X, 5 (polyester coated Aluminum) (FM/CSA pending)
X Explosionproof NEMA 7, 9 (polyester coated Aluminum) (FM/CSA pending) (See Note 2)
S General Purpose NEMA 4X 304 S.S. (Integral only) (FM/CSA pending) (See Note 3)

Enclosure
I Integral
R Remote (See Note 1)

Output
1 4-20 mA and (2) SPDT relays
2 (4) SPDT relays

Radar Tracker Series
LCR

- Note 1: Total length of remote coaxial cable and probe insertion length cannot exceed 33 feet. Order remote coaxial cable assembly as a sererate item (LCR210030) and specify length.
Note 2: FM and CSA approval pending for (CL 1 & 2, Div 2, Group C, D, E, F, G).
Note 3: The 304 S.S. enclosure is only available as an integral unit.
Note 4: Maximum length of 12 feet (3.7 m) on rigid rod probes.
Note 5: Maximum length of 33 feet (10.2 m) on flexible cable probes.

5.0 PROGRAMMING PARAMETER DESCRIPTIONS

ENTER

The *ENTER* key is used to move between sub-menu items. It is also used to accept any numeric programming input values.

RLY1

This term is used to describe Relay #1 in the programming menu.

1_ON (This term is used to describe where relay 1 turns on.)

1OFF (This term is used to describe where relay 1 turns off.)

RLY2

This term is used to describe Relay #2 in the programming menu.

2_ON (This term is used to describe where relay 2 turns on.)

2OFF (This term is used to describe where relay 2 turns off.)

RLY3

This term is used to describe Relay #3 in the programming menu.

3_ON (This term is used to describe where relay 3 turns on.)

3OFF (This term is used to describe where relay 3 turns off.)

RLY4

This term is used to describe Relay #4 in the programming menu.

4_ON (This term is used to describe where relay 4 turns on.)

4OFF (This term is used to describe where relay 4 turns off.)

SPAN

%_HI (This term is used to set the 20 mA or high/upper value.)

%_LO (This term is used to set the 4 mA or low/bottom value.)

STEP

The *STEP* key is used to move between main menu items. It is also used to increase or decrease numeric values. By *pressing* the *STEP* key, the numeric value increases by single digits. By *holding* the *STEP* key, the numeric value increases by 10's.

EXIT

The EXIT *parameter* is used to exit the programming menu and return to normal operating mode.

- Note 1:** The relays can be set inside or outside the operating range of the 4-20 mA span.
- Note 2:** All input values reference (or start) from the bottom of the rod. (i.e. 0% = bottom of probe, 100% = top of tank or probe)
- Note 3:** The 4 mA value must always be lower than the 20 mA value.
- Note 4:** When performing the rod re-initialization routine after cutting or shortening the probe, the transmitter automatically re-measures the length of the rod using a software routine. The span defaults 4 mA to the bottom of the rod, and 20 mA defaults to the top of the rod.
- Note 5:** All relays utilize failsafe logic. Failsafe relay logic is defined such that if the electrical power fails, the relays turns off. In High Level failsafe logic, this causes the output to indicate as if the tank were full. In Low Level failsafe logic, this causes the output to indicate as if the tank were empty.

5.1 CALIBRATION

Note: This unit can be programmed on a workbench or while it is installed in the vessel. Product does NOT need to be present to calibrate the unit.

In Tank Calibration...

1. Connect the properly sized Wave Guide to the transmitter base.
2. Install transmitter onto the tank using a metallic flange or metallic half coupling.
3. Connect power supply to terminals L1 and L2.
4. Install current loop and relay wiring per diagram LCR2E0000.
5. Complete the calibration sequence using Figure #1. If the transmitter is the 4 relay version, use Figure #2. Please note that product can be in the vessel, or the vessel can be empty. Product material does not need to be present for setup and programming.
6. Check calibration by varying material level and watching the output.

Bench Calibration...

1. Connect the properly sized Wave Guide to the transmitter base.
2. Lay the transmitter on a workbench or table. It does not need to be suspended from the ceiling.
3. Install power supply per wiring diagram LCR2E0000.
4. Program the span using the %_HI and %_LO parameters. Refer to Figure #1 (or Figure #2) for the proper programming sequence.
5. If necessary, program the output relays.
6. Verify the calibration by running your hand up and down the rod between the calibration setpoints. The output reading should change correspondingly.
7. After installing the unit on the tank, it is always best to cycle the tank several times and watch the operation of the transmitter.

Shortening the Probe...

1. Cut the probe and re-install unit on tank without any material present. This means the probe should be suspended in an open air environment.
2. Hold the ENTER key while applying power to the unit.
3. When CAL R appears on the display, release the ENTER button.
4. A series of random numbers between 300 and 10,000 will appear. Wait for the display to stabilize. This should take approximately 5 to 10 seconds. After which time, press the ENTER button again.
5. Program your span and/or relay setpoints using the flowchart in Section 5.2.

5.2 PROGRAMMING MATRIX

Refer to the "Programming Flowchart" on the following pages.

5.3 PROGRAMMING CONCERNS

- All programming parameters are set **as a percentage** of the total rod length.
- All programming parameters are set from **the bottom of the rod up** (and not from the top of the rod down).
(i.e. 0% = bottom of probe, 100% = top of tank or probe)

RADAR TRACKER
Calibration of 4-20 mA
and 2 relays (v1.17)

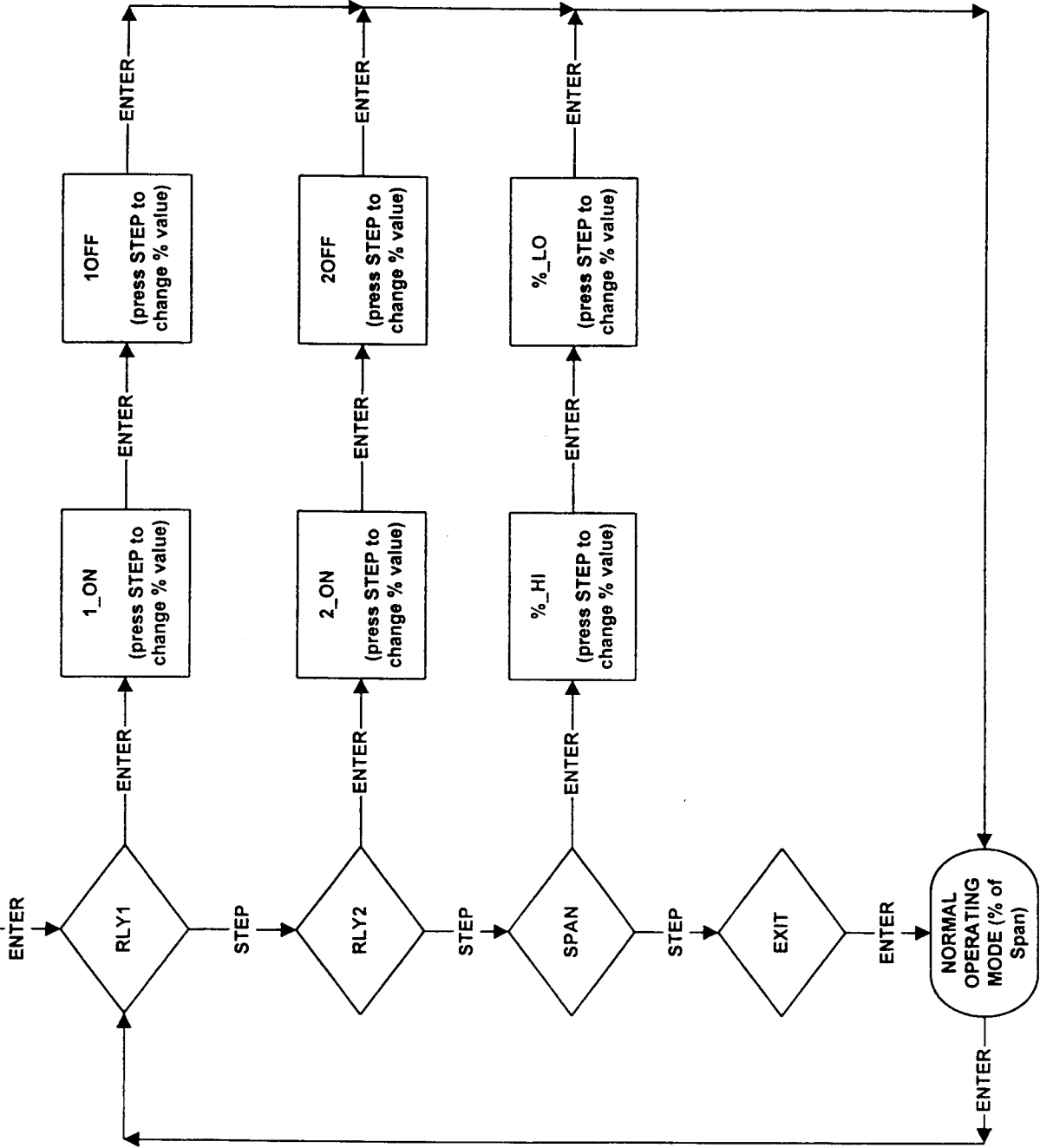

RADAR TRACKER
Calibration of
4 relay version
(v1.17)

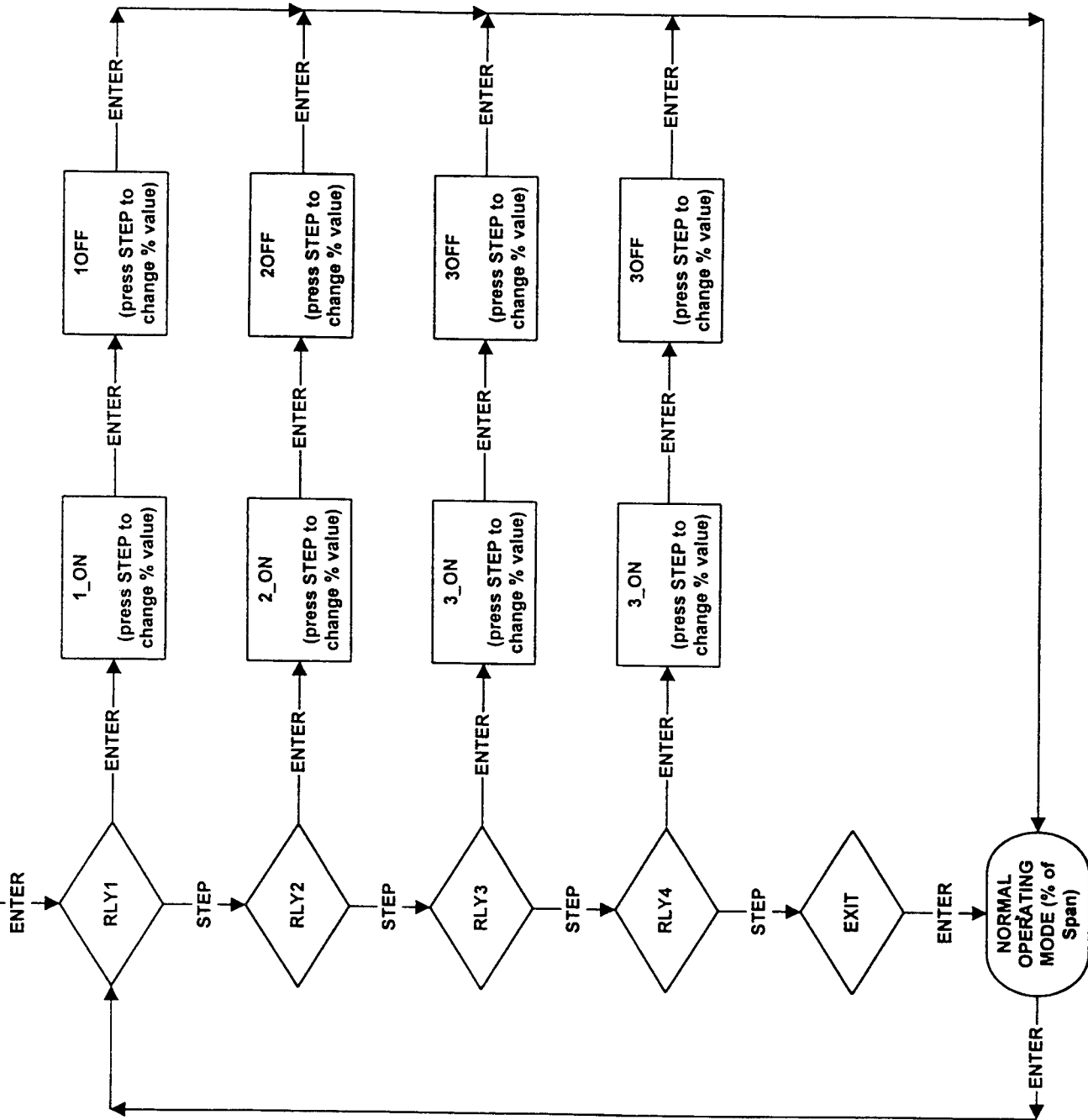

- All programming parameters are based on ***the amount of the probe to be covered by material.***

TRL = total rod length (in inches)

USP = upper set point (in inches)

LSP = lower set point (in inches)

AP = actuation point (in inches)

$$\%_HI = 100 - (((TRL - USP) / TRL) \times 100)$$

$$\%_LO = 100 - (((TRL - LSP) / TRL) \times 100)$$

$$1_ON = 100 - (((TRL - AP) / TRL) \times 100)$$

$$1OFF = 100 - (((TRL - AP) / TRL) \times 100)$$

$$2_ON = 100 - (((TRL - AP) / TRL) \times 100)$$

$$2OFF = 100 - (((TRL - AP) / TRL) \times 100)$$

If you are using the 4 relay version then...

$$3_ON = 100 - (((TRL - AP) / TRL) \times 100)$$

$$3OFF = 100 - (((TRL - AP) / TRL) \times 100)$$

$$4_ON = 100 - (((TRL - AP) / TRL) \times 100)$$

$$4OFF = 100 - (((TRL - AP) / TRL) \times 100)$$

6.0 APPLICATION ERRORS

- Verify that the unit is compatible with the process including pressure, temperature, construction, and area classification.
- Maintain a minimum clearance of 6" (152 mm) between wave guide and tank wall.
- Do not reduce the Wave Guide shorter than 6" (152 mm).

- The single Wave Guide unit has a 3” deadband at the bottom of the probe. As long as the liquid or dry bulk material never leaves the bottom of the probe, the deadband will not appear. If product does leave the bottom of the probe, the unit will be able to read to the very end of the rod. The three ways to eliminate the deadband is to: a.) never allow the liquid to leave the end of the rod, or set your 4 Ma point 3” up on the rod, b.) install a reflector plate to reflect the signal back, c.) adjust the rod length so that it touches the bottom of the tank. The tank bottom will reflect the signal back when the tank is empty.

7.0 TROUBLESHOOTING

Troubleshooting the **transmitter** - -

- Verify input power with a volt meter. The accepted tolerance is $\pm 10\%$.
- This transmitter requires a metallic mounting surface for proper operation. Verify that a 3” or greater metallic ANSI flange (or a 6” diameter metal plate or surface) is used to provide proper “launching” of the radar signal. A $\frac{3}{4}$ ” NPT half coupling on a metal roof will also work well. For the heavy duty version, a 1 $\frac{1}{4}$ ” NPT half coupling will work well.
- The minimum insertion length is 6”.
- The minimum stilling well inner diameter needs to be 4” or greater.
- The minimum wall distance required is 6” to avoid interference due to wall buildup, material bridging, or wall irregularities.
- Verify that the minimum product dielectric is 10 or greater when using the single rod probe.
- There is a 3” deadband at the bottom of the probe. This area may be unspannable. Contact the factory for further assistance.

Troubleshooting the **current loop** - -

- Verify the total impedance of the output loop is 500 ohms or less on the line powered version.
- Verify proper connection of current loop output wiring.
- The Radar Tracker sources its own output loop, do not place a voltage on the loop.
- Ground the output loop on the readout or display side to avoid ground loop problems.

Troubleshooting the output relays - -

- Relays are dry, unpowered contacts. Verify that an input voltage is provided for the COMMON terminal.
- Verify proper connection of relay output wiring, including the NO or NC terminals.
- The relay contacts are rated for a 10A non-inductive load.
- Verify that the relay LED is ON when the relay is energized. If the LED is never ON, verify the relay programming. Make sure the ON and OFF setpoints are within the working range of the liquid level.
- The relays can be set *inside* or *outside* the operating range of the 4-20 mA span.

8.0 REPLACEMENT PARTS

LAR131415	Silicone Rubber Gasket, Cover (special)
LAR131421	Neoprene Gasket, Cover (standard)
LCR210005	Transmitter Circuit Board – mA & 2 relay – 120 VAC
LCR210006	Transmitter Circuit Board – mA & 2 relay – 240 VAC
LCR210007	Transmitter Circuit Board – 4 relay – 120 VAC
LCR210008	Transmitter Circuit Board – 4 relay – 240 VAC
LCR210022	Wave Guide, Cable/Weight for ¾" NPT standard probe
LCR210023	Wave Guide, Cable/Weight for 1 ¼" NPT heavy duty probe
LCR220008	Wave Guide, rigid rod, 12' maximum, 3/8" DIA, 316 S.S.
LCR220009	Wave Guide, rigid rod, 12' maximum, ½" DIA, ¼-20 THD, 316 S.S., for ¾" NPT standard bin connector
LCR220027	Wave Guide, rigid rod, 12' maximum, ½" DIA, 3/8-16 THD, 316 S.S., for 1 ¼" NPT heavy duty bin connector
LCR230006	Protective (plastic) Safety Shield for electronic unit
LCR280000	Radar Tracker Installation & Operation Manual
LCR280002	Radar Tracker Application Data sheet
LUA030240	¼-20 x 1" long 316 S.S. cover bolts (6 required)
LUC036636	Fuse, 63 Ma (0.063 A), 250 VAC

9.0 FACTORY ASSISTANCE

After reviewing the Troubleshooting (Section 6) and Application Errors (Section 7) of the installation manual, factory assistance can be reached via

phone at (810) 987-2700 or (864) 574-8960. Please have your model number and application details available.

10.0 WARRANTY & PARTS

Refer to the Manufacturer's General Terms and Conditions of Sales for warranty information. The Radar Tracker is designed to give you years of unattended service. No scheduled maintenance or parts and service are required.

11.0 DRAWINGS

<u>Drawing Number</u>	<u>Description</u>
LCR2E0000	Electrical Hookup Drawing
LCR2E0003	Cable/Weight (Std.) Probe Outline Drawing
LCR2E0004	Rigid Rod Probe (3/8" DIA) Outline Drawing
LCR2E0005	Rigid Rod Probe (1/2" DIA) Outline Drawing
LCR2E0006	Cable/Weight Probe (1 1/4" NPT) Outline Drawing
LCR2E0007	Flange, Dimensional Outline Drawing (3/4" NPT)
LCR2E0008	Flange, Dimensional Outline Drawing (1 1/4" NPT)
LCR2E0009	Sanitary Probe (2") Outline Drawing
LCR2E0010	Rigid Rod Probe (3/8" DIA) with 6" Hi-Temp Lagging Assembly Outline Drawing

12.0 GENERAL TERMS AND CONDITIONS OF SALE

/rjw 07-23-98

REVISIONS

DATE: K'D APP'D

.89 (22.61)
 1.88 (47.75)
 .94 (23.88)
 3/4" N.P.T.
 2-PLACES

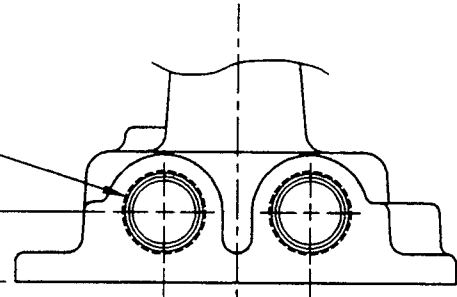

CONDUIT ENTRY(S)

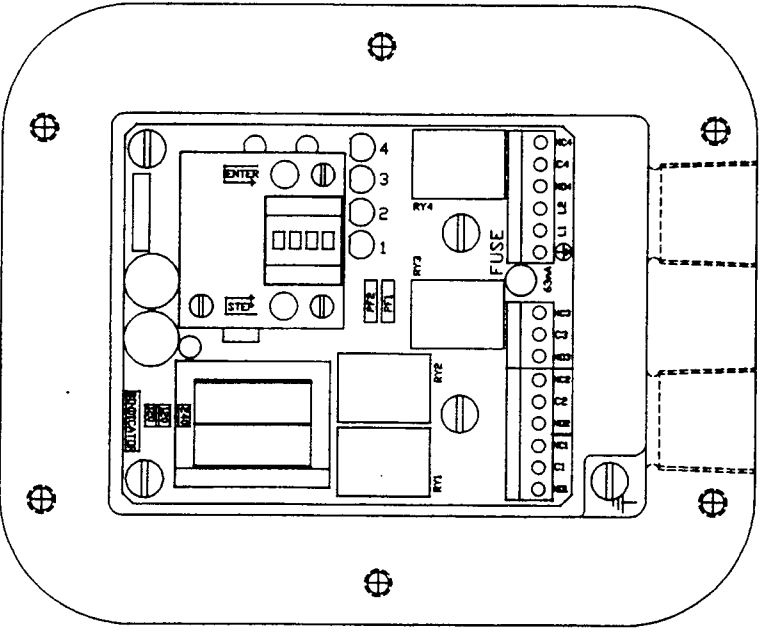

4-RELAY VERSION

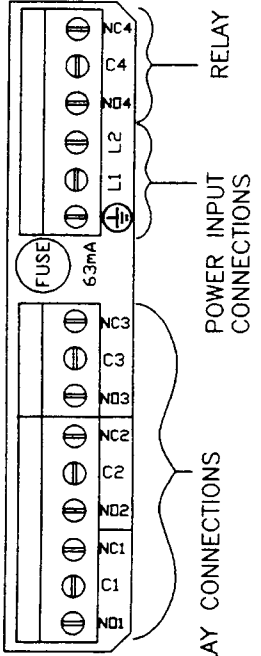

RELAY CONNECTIONS POWER INPUT CONNECTIONS

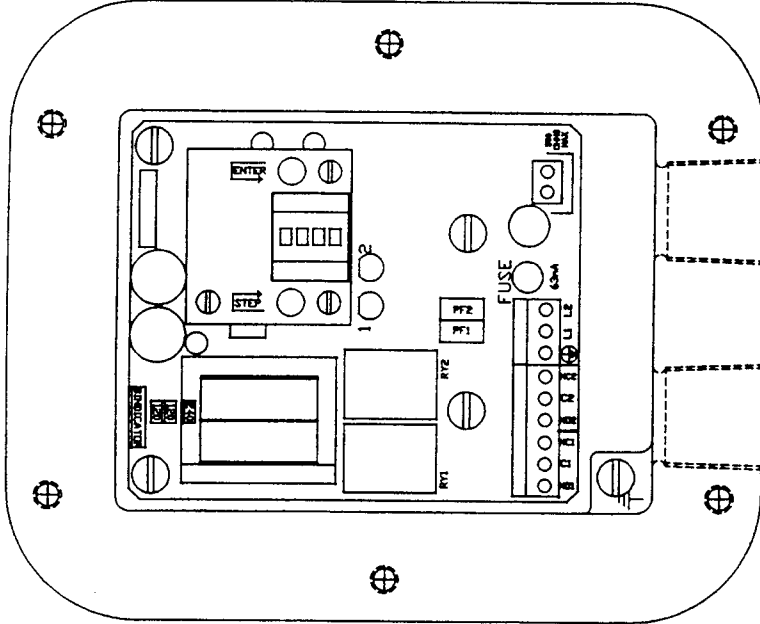

2-RELAY & 4-20 mA VERSION

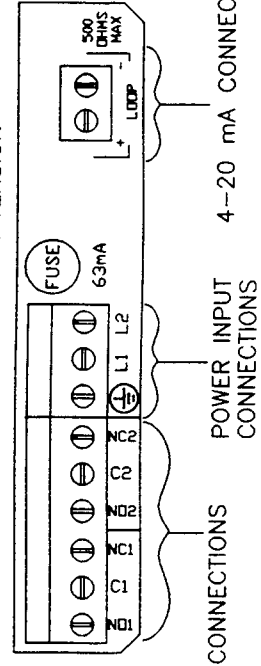

RELAY CONNECTIONS POWER INPUT CONNECTIONS 4-20 mA CONNECTION

BRACKETED DIMS ARE IN MILLIMETERS.
 DO NOT SCALE DIM'S. ARE IN INCHES.

DET. REQ'D	SHI	DESCRIPTION	MATERIAL	PART
UNSPECIFIED TOL.	DRAWN	APPROVED	PROD.	MARKET
DECIMALS SHOWN	ARIC C.	NEW	WASHKETCH	
ANGLES & L/S	DATE	DATE	DATE	DATE
BEHIND & BREAK	5/28/98	6-1-98	6-1-98	5/29/98
EDGES .005	SCALE	SIZE	PARTY OR DRAWING	
	NONE	B	L	LCR2E0000

HOOKEUP DRAWING
 RADAR TRACKER

BINDICATOR®
 PORT HURON, MICHIGAN 48060

REVISIONS

DATE/CHK'D APP'D

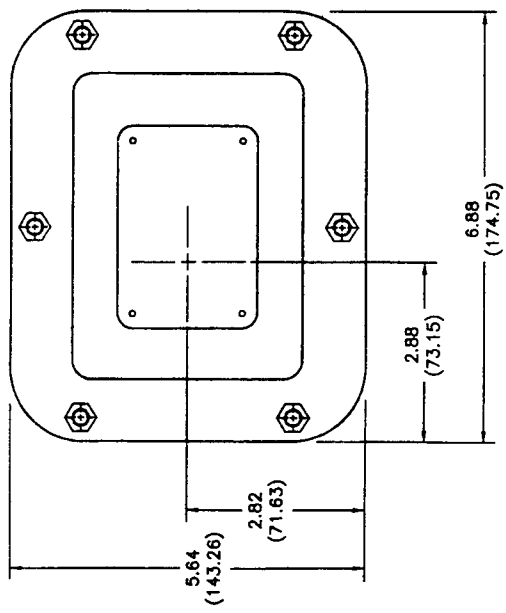
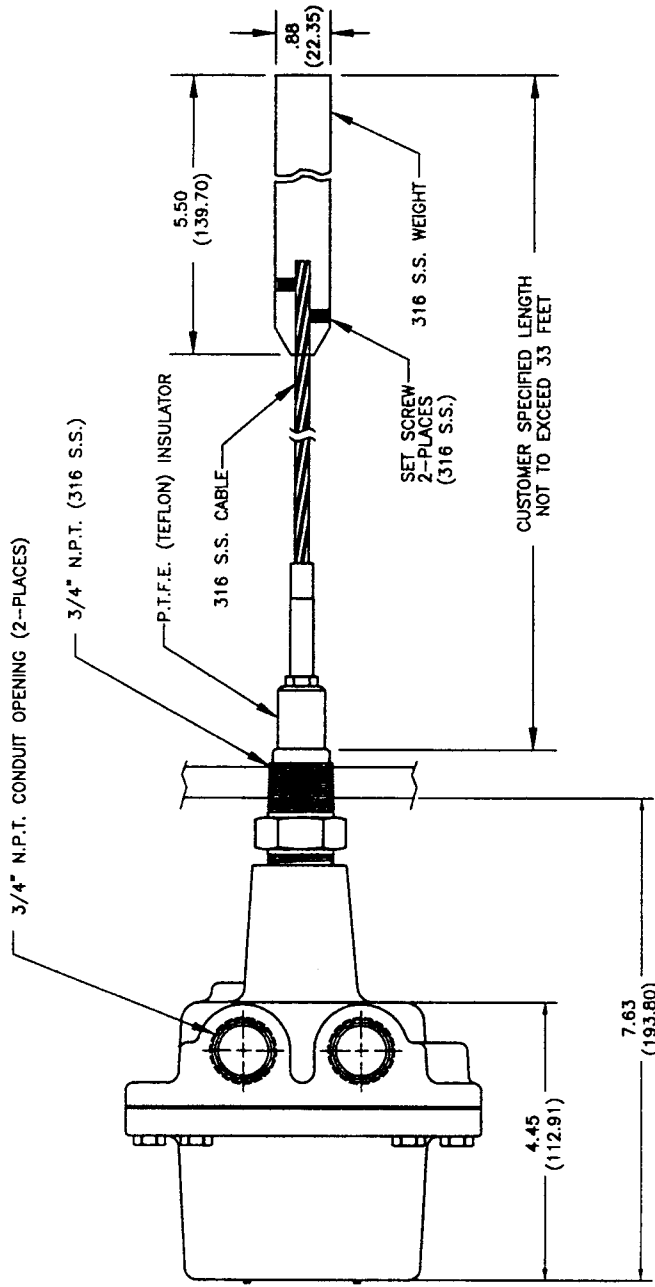

BRACKETED DIMS ARE IN MILLIMETERS.
DO NOT SCALE DIMS. ARE IN INCHES.

MATERIAL		FINISH	
G.P. INTEGRAL WITH CABLE/WEIGHT PROBE		G.P. INTEGRAL WITH CABLE/WEIGHT PROBE	
DESIGNED BY	DATE	DESIGNED BY	DATE
ARC C.	5/21/98	ARC C.	5/21/98
CHECKED	DATE	CHECKED	DATE
BOB L.	5-26-98	BOB L.	5-26-98
APPROVED	DATE	APPROVED	DATE
H. J. W. L.	5-26-98	H. J. W. L.	5-26-98
PROB'D	DATE	PROB'D	DATE
WASHKEVICH	5/22/98	WASHKEVICH	5/22/98
MAT. OR PART	SCALE	MAT. OR PART	SCALE
B	HALF	B	HALF
TITLE OUTLINE RADAR TRACKER TRANSMITTER		TITLE OUTLINE RADAR TRACKER TRANSMITTER	
G.P. INTEGRAL WITH CABLE/WEIGHT PROBE		G.P. INTEGRAL WITH CABLE/WEIGHT PROBE	
PART OR DRAWING		PART OR DRAWING	
L		L	
LCR2E0003		LCR2E0003	

REVISIONS

DATE CHECK'D APP'D

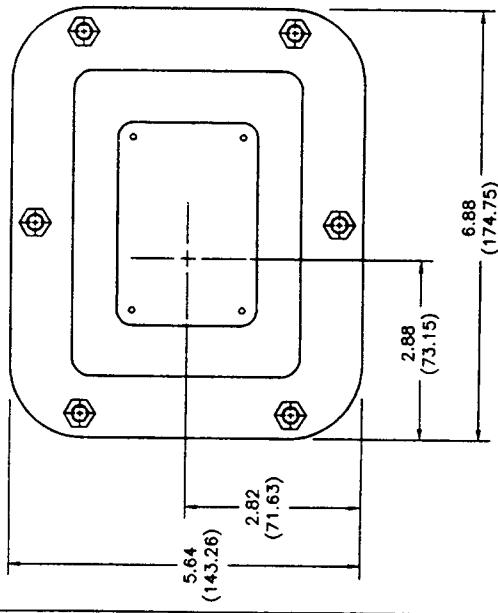
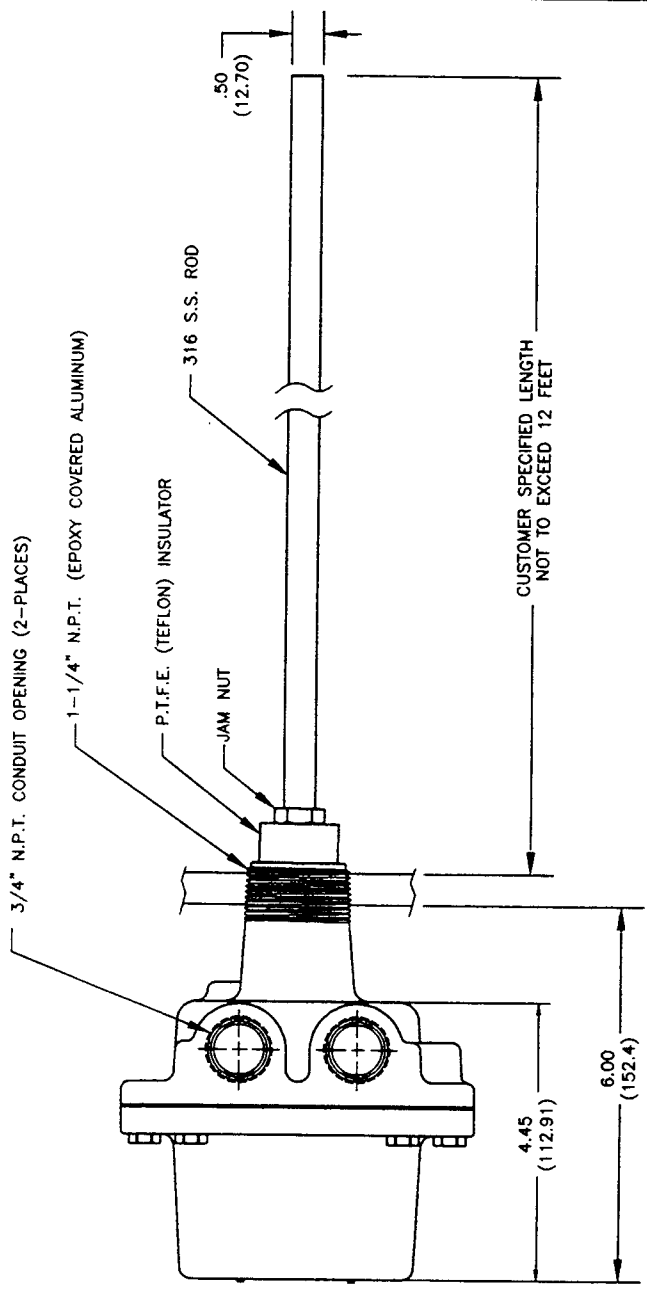

BRACKETED DIMS ARE IN MILLIMETERS.
DO NOT SCALE DIMS. ARE IN INCHES

MATERIAL		FINISH		UNSPECIFIED TOL. DECIMALS TO 3 ANGLES ± 1/2° HOLE & BREAK EDGES .005		DET. REQ'D SHIT		DESCRIPTION		MATERIAL PART	
BINDERATOR® PORT HURON, MICHIGAN 48060		BINDERATOR® PORT HURON, MICHIGAN 48060		BINDERATOR® PORT HURON, MICHIGAN 48060		DRAWN ARIC C. DATE 7/15/98		APPROVED S.M.H. DATE 7/20/98		MARKET WASHKEVICH DATE 07-15-98	
TITLE OUTLINE RADAR TRACKER TRANSMITTER H.D. INTEGRAL G.P. 1/2" DIAMETER RIGID ROD				SCALE		SCALE		SIZE		PART OR DRAWING	
				HALF		HALF		B		LCR2E0005	

REVISIONS

DATE: 5/22/98

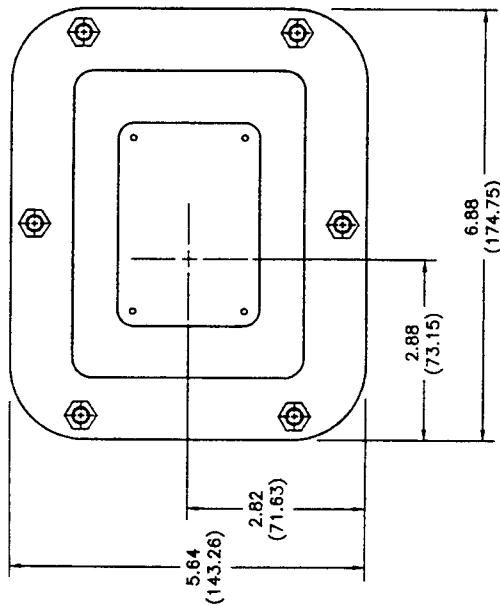
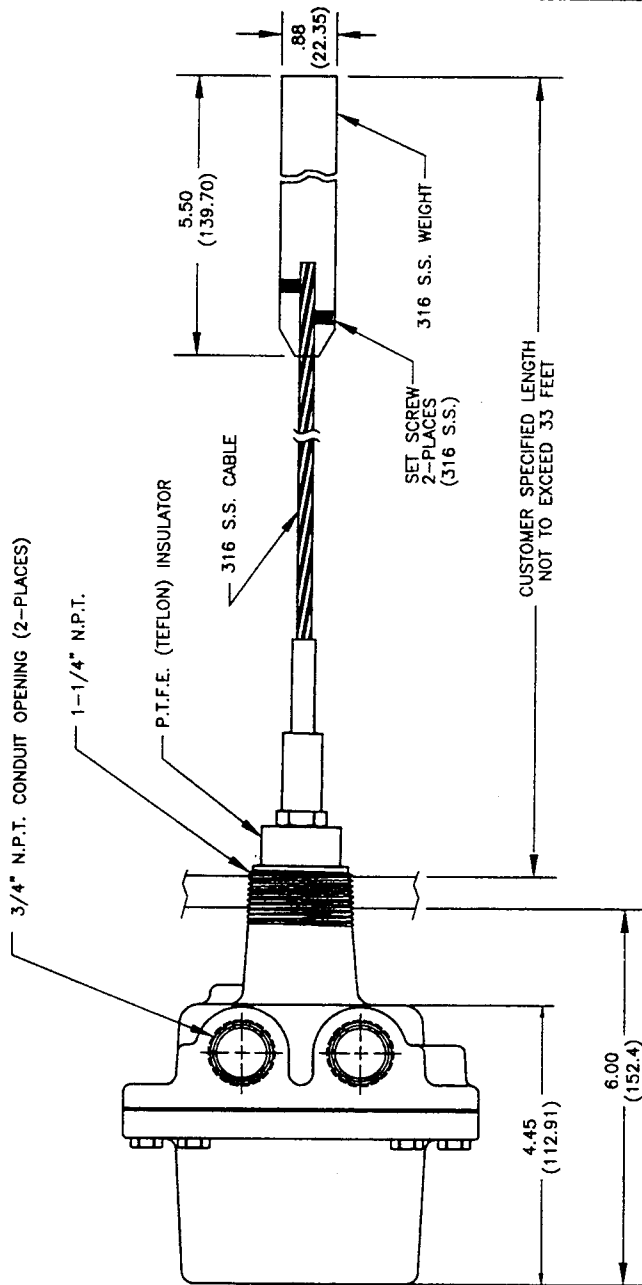

BRACKETED DIMS ARE IN MILLIMETERS.
DO NOT SCALE DIMS. ARE IN INCHES.

MATERIAL	FINISH	UNCLASSIFIED TO: MIL-STD-883C METHOD 2000 CLASS A ANGLES + 1/2° PER HOUR EXCESS 100	DESIGN	APPROVED	PROJ.	MATERIAL PART
			ARIC C.	C. J. R.	5-22-98	WASHKEVICH
TITLE: OUTLINE RADAR TRACKER TRANSMITTER H.D. INTEGRAL WITH CABLE/WEIGHT PROBE			DATE	DATE	DATE	DATE
BINDICATOR® PDRT HURON, MICHIGAN 48060			5-22-98	5-26-98	26 MAY 97	5/22/98
SCALE			SIZE	PART OR DRAWING		
HALF			B	LCR2E0006		

REVISIONS		DATE	BY	APP'D

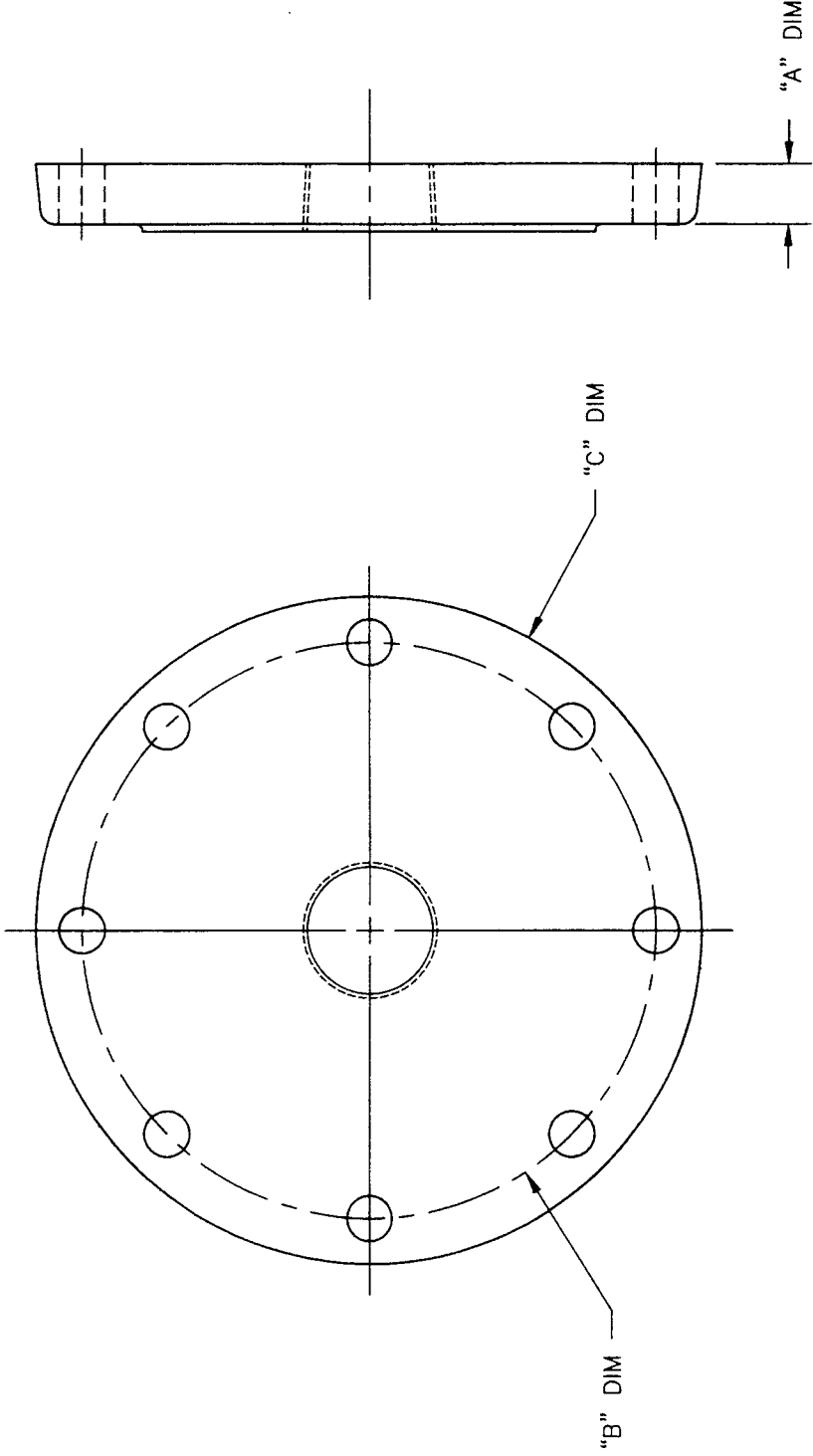

DESCRIPTION	"A" DIM	"B" DIM	"C" DIM	NO.	DRG.	BOLTS
FLANGE, 12" SCH40/80 150	1.250	17.000	19.00	12	.88	
FLANGE, 10" SCH40/80 150	1.187	14.250	16.00	12	.88	
FLANGE, 8" SCH40/80 150	1.125	11.750	13.50	8	.75	
FLANGE, 6" SCH40/80 150	1.00	9.50	11.00	8	.75	
FLANGE, 4" SCH40/80 150	.937	7.50	9.00	8	.63	
FLANGE, 3" SCH40/80 150	.937	6.00	7.50	4	.63	

DO NOT SCALE DIM'S. ARE IN INCHES

MATERIAL	FINISH	UNSPECIFIED TOL. DECIMALS TO 1/16" ANGLES TO BREAK DIMS .005	DRAWN	CHECKED	APPROVED	PROD.
METALLIC FLANGE			ARIC C.	C. HALL	HEWLETT	RENTON
			DATE	DATE	DATE	DATE
			5/22/98	5-26-98	5-26-98	5/22/98
TITLE			SCALE		PART OR DRAWING	
RADAR TRACKER 3/4" N.P.T. MOUNT			NONE		B	
BINDERATOR® PORT HURON, MICHIGAN 48060			LCR2E0007			

REVISIONS

DATE	CK'D	APP'D

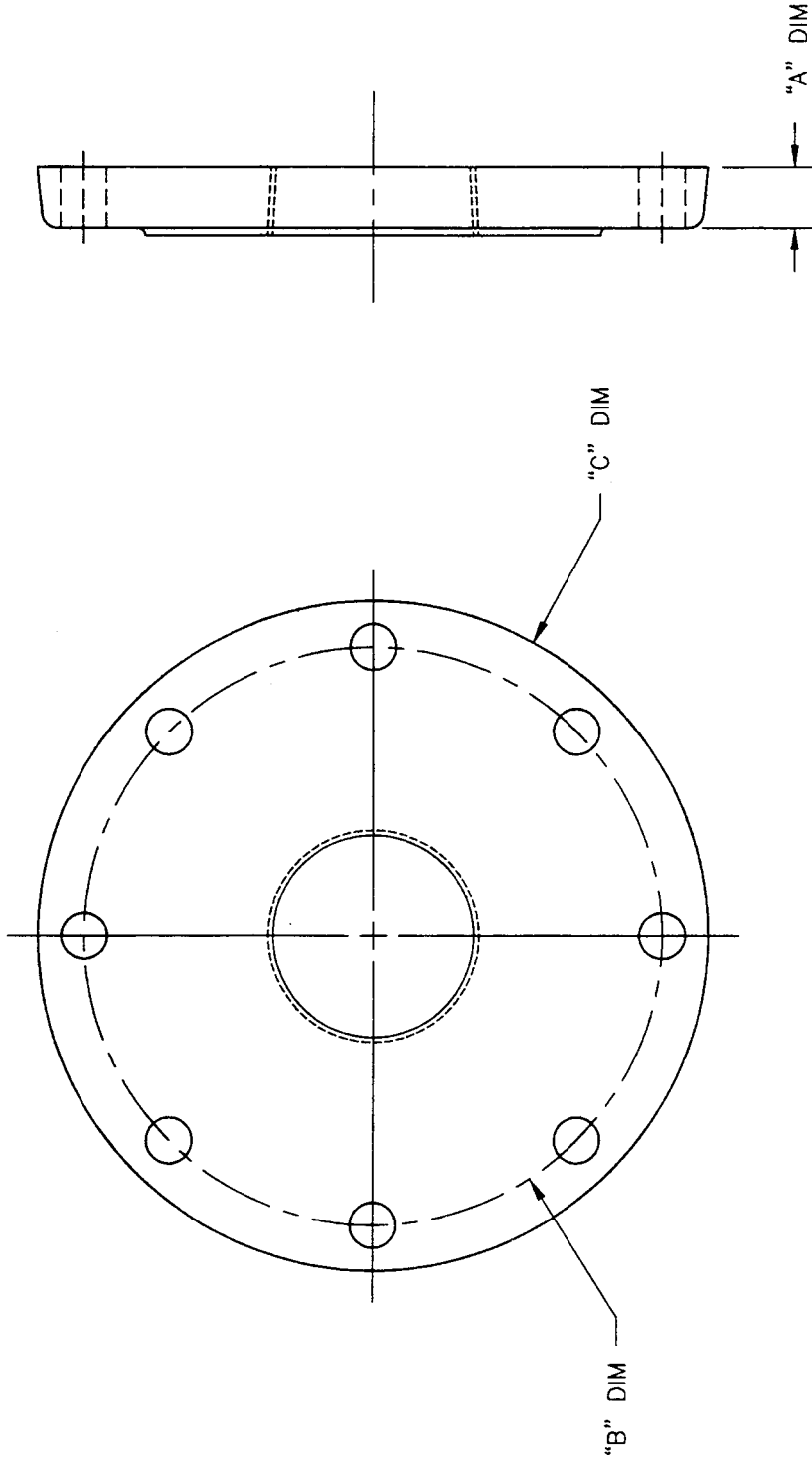

DESCRIPTION	"A" DIM	"B" DIM	"C" DIM	NO.	DR.
FLANGE, 12" SCH40/80 150#	1.250	17.000	19.00	12	.88
FLANGE, 10" SCH40/80 150#	1.187	14.250	16.00	12	.88
FLANGE, 8" SCH40/80 150#	1.125	11.750	13.50	8	.75
FLANGE, 6" SCH40/80 150#	1.00	9.50	11.00	8	.75
FLANGE, 4" SCH40/80 150#	.937	7.50	9.00	8	.63
FLANGE, 3" SCH40/80 150#	.937	6.00	7.50	4	.63

DO NOT SCALE DIM'S. ARE IN INCHES

MATERIAL	FINISH	UNSPRINTED TOL. DECIMALS: .001 ANGLES: DEGREE & BREAK EDGES: .005	DRAWN BY: ARIC C. DATE: 5/22/98	CHECKED BY: RUSSELL DATE: 5-26-98	APPROVED BY: DATE: 5-26-98	PROJ. NO. 240000077	MARSH. WASHKEVICH DATE: 5/22/98	
METALLIC FLANGE						SCALE: NONE	SIZE: B	
 BIDICATOR PORT HUON, MICHIGAN 48080							TITLE: RADAR TRACKER 1-1/4" N.P.T. MOUNT PART OR DRAWING: LCR2E0008	

REVISIONS

DATE: 5/27/98

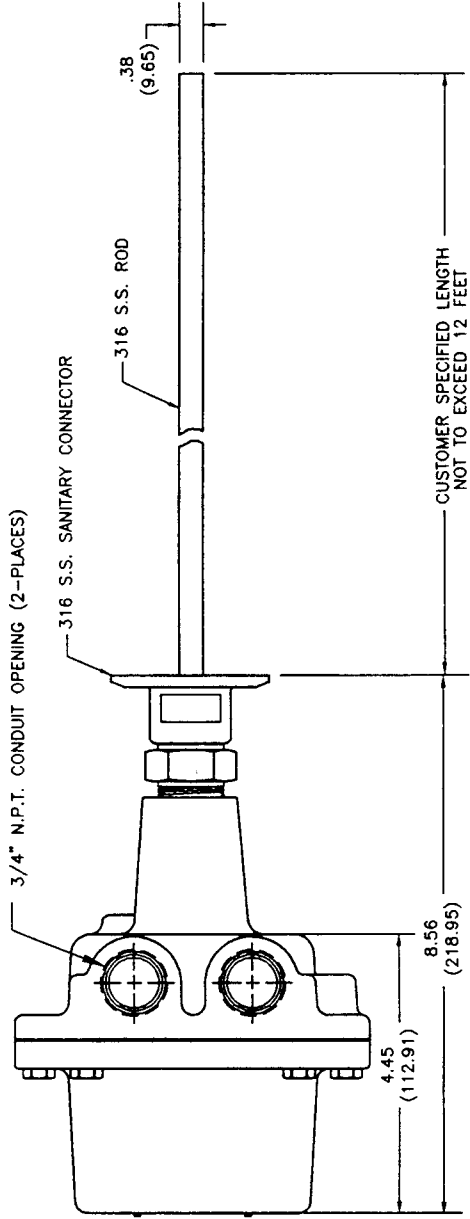
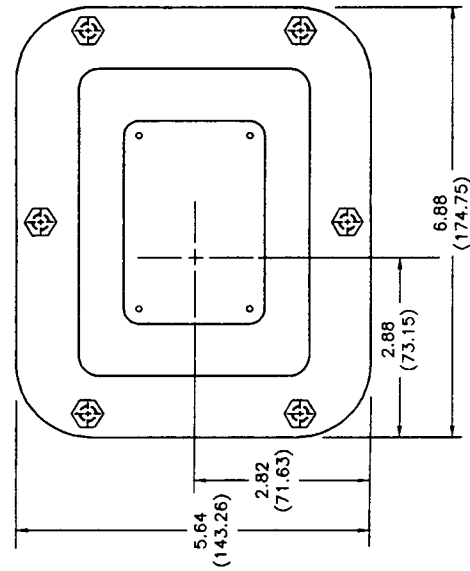
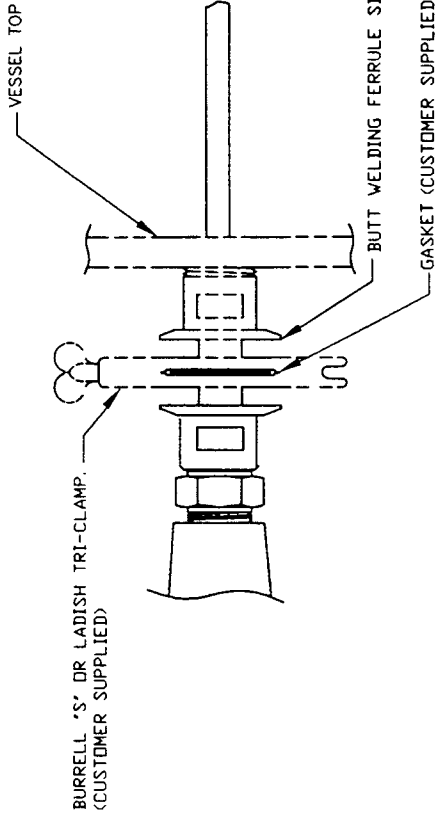

BRACKETED DIMS ARE IN MILLIMETERS. DO NOT SCALE DIM'S. ARE IN INCHES.

MATERIAL		FINISH		UNSPECIFIED TO: MECHANICALS, ANGLES, NUMBER & EDGE ROUNDS		DRAWN: ARIC C. DATE: 5/22/98		CHECKED: C. RUSSELL DATE: 5-28-98		APPROVED: HENWELL DATE: 6-1-98		DESCRIPTION: RADAR TRACKER TRANSMITTER SANITARY PROBE		DET. REQ'D SHIT: SCALE: HALF		MATERIAL PART: WASHKEVICH DATE: 5/27/98	
BINDERATOR®				TITLE: OUTLINE				PART OR DRAWING: B				LCR2E009					

REVISIONS

DATE/CHK'D APP'D

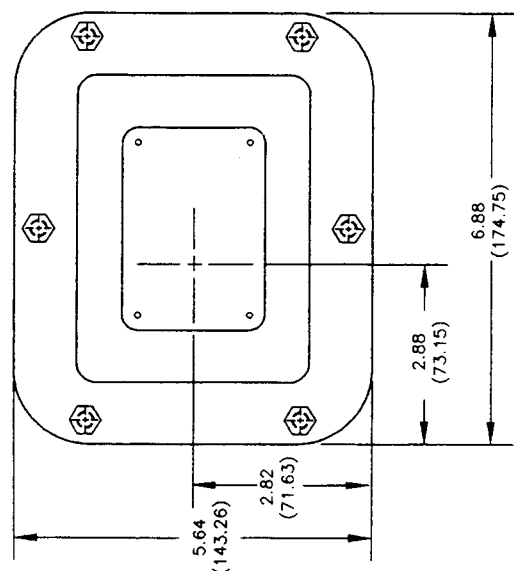
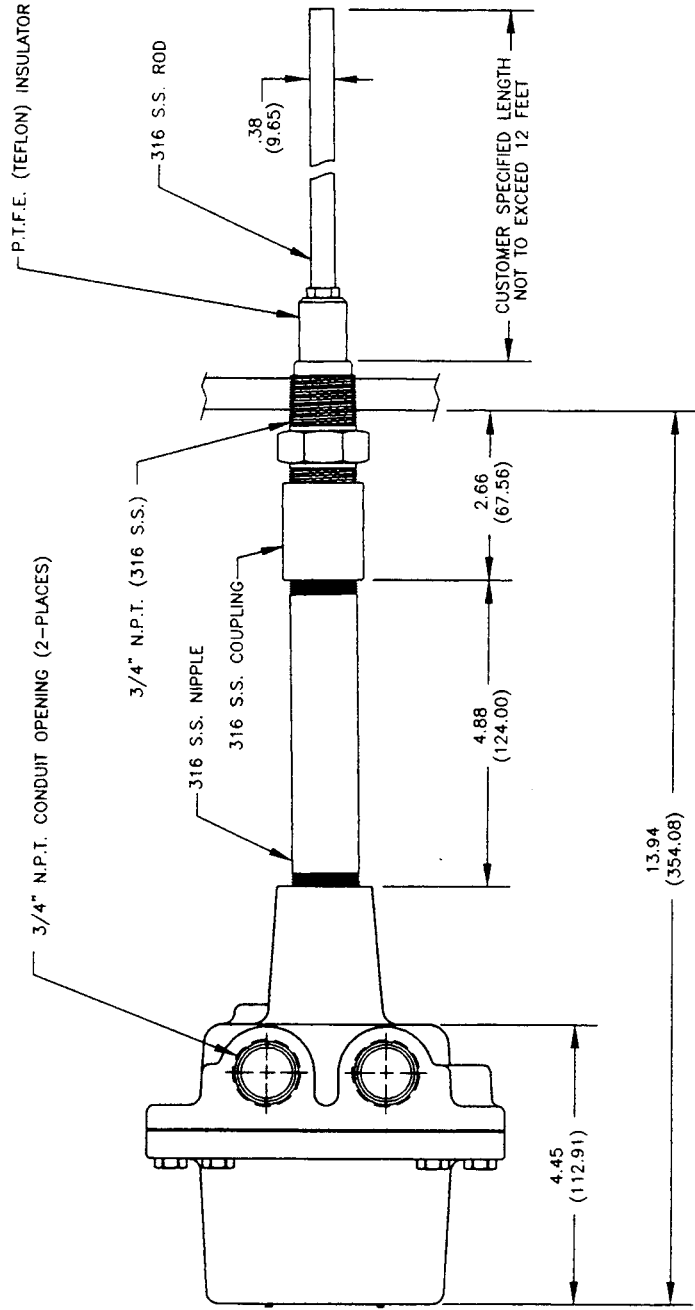

BRACKETED DIMS ARE IN MILLIMETERS.
DO NOT SCALE DIMS. ARE IN INCHES

MATERIAL		FINISH		UNSPECIFIED TOL. DECIMALS XXX ANGLES 1/4° DIMENSIONS & BREAK EDGES .005		DET. REQ'D SHIT		DESCRIPTION		MATERIAL PART	
						DRAWN		APPROVED		HARREY	
						DATE		DATE		WASHKEVICH	
						6/25/98		7/7/99		DATE	
								7-7-98		DATE	
								7 JULY 98		DATE	
								PART OR DRAWING		DATE	
								SCALE		DATE	
								HALF		07-01-98	
								SIZE		DATE	
								B		07-01-98	
								TITLE		DATE	
								OUTLINE RADAR TRACKER TRANSMITTER		07-01-98	
								G.P. INTEGRAL 3/8" DIAMETER RIGID ROD		DATE	
								W/6" LAGGING ASSY.		DATE	
								SCALE		DATE	
								HALF		DATE	
								SIZE		DATE	
								B		DATE	
								TITLE		DATE	
								OUTLINE RADAR TRACKER TRANSMITTER		DATE	
								G.P. INTEGRAL 3/8" DIAMETER RIGID ROD		DATE	
								W/6" LAGGING ASSY.		DATE	
								SCALE		DATE	
								HALF		DATE	
								SIZE		DATE	
								B		DATE	
								TITLE		DATE	
								OUTLINE RADAR TRACKER TRANSMITTER		DATE	
								G.P. INTEGRAL 3/8" DIAMETER RIGID ROD		DATE	
								W/6" LAGGING ASSY.		DATE	
								SCALE		DATE	
								HALF		DATE	
								SIZE		DATE	
								B		DATE	
								TITLE		DATE	
								OUTLINE RADAR TRACKER TRANSMITTER		DATE	
								G.P. INTEGRAL 3/8" DIAMETER RIGID ROD		DATE	
								W/6" LAGGING ASSY.		DATE	
								SCALE		DATE	
								HALF		DATE	
								SIZE		DATE	
								B		DATE	
								TITLE		DATE	
								OUTLINE RADAR TRACKER TRANSMITTER		DATE	
								G.P. INTEGRAL 3/8" DIAMETER RIGID ROD		DATE	
								W/6" LAGGING ASSY.		DATE	
								SCALE		DATE	
								HALF		DATE	
								SIZE		DATE	
								B		DATE	
								TITLE		DATE	
								OUTLINE RADAR TRACKER TRANSMITTER		DATE	
								G.P. INTEGRAL 3/8" DIAMETER RIGID ROD		DATE	
								W/6" LAGGING ASSY.		DATE	

BINDICATOR®
PORT HURON, MICHIGAN 48060

GENERAL TERMS AND CONDITIONS OF SALE

1. PAYMENT Terms of payment are Net 30 days and are effective from the actual date of invoice. If, in the Seller's opinion, the financial condition of the Buyer at any time-or any other circumstances do not justify the incurrence of production costs or shipment on the terms of payment specified, the Seller may require partial or full payment in advance.

2. F.O.B. All shipments are F.O.B. Seller's factory in Port Huron, Michigan, unless otherwise stated in the quotation.

3. QUOTATION AND PRICES Quoted prices are firm for thirty days and are subject to change without notice after expiration of this period. Orders calling for future deliveries will be invoiced according to prices in effect at the time of shipment.

4. TAXES Any applicable sales, use, revenue, excise or other taxes not specifically stated in the quotation are to be remitted by the Buyer directly to the appropriate regulatory agency.

5. EQUIPMENT WARRANTY/LIMITATION The following BINDICATOR products are warranted for a period of two years from date of shipment against defective materials and workmanship: RF Series, Mark III Yo-Yo, General Purpose Yo-Yo, Micro-Sonic Series, Eagle, Mach One, Leveldata, Tracker, and Levelite Series. All CELTEK and other Bindicator products are warranted for a period of one year from date of shipment against defective materials and workmanship. WE MAKE NO OTHER WARRANTY, EXPRESS OR IMPLIED, AND ANY WARRANTY OF MERCHANTABILITY OR FITNESS FOR A PARTICULAR PURPOSE WHICH EXCEEDS THE FOREGOING IS HEREBY DISCLAIMED AND EXCLUDED FROM THIS CONTRACT. If the products are being acquired for resale, Buyer will make, in connection with any such resale, only those warranties contained herein and will indemnify us against any claims, causes of actions and judgements which arise from any representations, warranties or agreements made by or entered into by Buyer, other than those contained herein.

6. BUYER'S EXCLUSIVE REMEDY In the event of any breach of warranty, the sole and exclusive remedy of Buyer (or any person claiming through Buyer) shall be limited to the repair or replacement of defective products or parts, at our plant or at Seller's option, to the refund of the purchase price, provided that notice of such defects is given within six months after shipment. In no event will our liability include any incidental or consequential damages.

7. DELIVERY The Seller shall not be liable for loss or damage of any kind resulting from delay or inability to deliver or account of flood, fire, strike, labor troubles, riot, civil disturbances, accidents, acts or orders or regulations of civil or military authorities, shortages of materials, or any other cause or causes (whether or not similar in nature to any of these enumerated) beyond Seller's control.

8. PRODUCT CHANGES In keeping with our continuing policy of product improvement, we reserve the right to make changes in our products at any time, without incurring an obligation to change equipment previously shipped.

9. RETURN OF GOODS In no case may products or parts be returned without Seller's prior written permission. Products or parts returned under the aforementioned Equipment Guarantee must be shipped with transportation charges prepaid. All other returns must be shipped with transportation charges prepaid and will be subject to a restocking charge. Only products of standard Bindicator manufacture will be accepted for return. Products which are specially modified or produced to the Buyer's specifications will not be accepted for return.

10. CONTRACT FORMATION A binding contract shall not be effective until a written purchase order is received at Seller's office in Port Huron, Michigan and accepted in writing by an authorized employee of the Seller at its Port Huron office. The terms and conditions in our quotation or acknowledgment shall govern the contract and any different or additional terms in Buyer's purchase order, unless approved by Seller in writing, are hereby objected to.

11. CONSTRUCTION Any agreement arrived at shall be considered to be a Michigan contract and shall be construed under the laws of the State of Michigan.

12. CANCELLATION Request for cancellation must be in writing and referred to Bindicator. No orders will be accepted with the understanding that they may later be cancelled. If and when cancellation is approved by Bindicator, it is with the understanding that Bindicator will be fully reimbursed by payment of cancellation charge: which are to be determined by Bindicator.

13. CERTIFICATION OF NONSEGREGATED FACILITIES Our firm does not maintain facilities of a segregated nature contrary to the provision of 41 CFR 60-1.8, and further that if we have 50 or more employees and our contractual arrangements of \$50,000 or more we have complied with 41 CFR 60-1.7 concerning the annual filing of a report on Standard Form 100 (EEO-1) and with 41 CFR 60-1.40 by developing a written Affirmative Action Compliance Program.

For information, specification, and engineering assistance
with any BINDICATOR® product...

Contact your local
distributor/representative
or
the factory.

Bindicator offers a complete range of Level and Flow Controls

Electro-Mechanical Level Controls

Roto-Bin-Dicator®
Mini-Roto-Bin-Dicator®
Super-Safe Roto-Bin-Dicator®
Model A Bin-Dicator®
Auto-Bin-Dicator®
Bantam Bin-Dicator®
Liquid Level Bin-Dicator®

RF Capacitance Level Controls

RF-4000	RF-9200
RF-6000	RF-10000
RF-8000	RF-11000
RF-8200	RF-12000
RF-9000	RF-17000
RF-9100	RF-18000

Sonic Level Controls MS-2000™ Series

Dry Flow

BinFlo®
Flo-Guard™
Flo-Commander™

Tuning Fork Level Controls

Pulse Point™

Continuous Level Controls

Bindicator Yo-Yo®
AR-1000®
Cap-Level® II & IIA
Radar Tracker®

Liquid Level Controls

Tracker® Mach One™
Leveldata Eagle™



150 Venture Boulevard
Spartanburg, SC 29306
Phone: (864) 574-8960, **Fax:** (864) 578-7308
Customer Service: (800) 778-9242
Internet: <http://www.bindicator.com>
email: sales@bindicator.com