

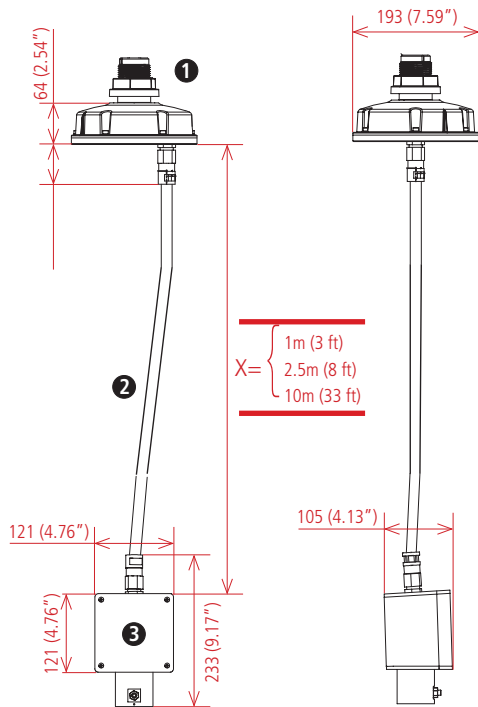

## Head Body Separation Kit



- ① Head Mounting
- ② Conduit
- ③ Antenna Connection Box

### Note

- The Head Body Separation Kit is available in 3 lengths: 1m (3 ft), 2.5m (8 ft) and 10m (33ft).
- **The lengths of the conduit are not to be altered.** Altering the length of the cable will affect the performance of the scanner and will void the approval rating.
- The Kit can be connected to any standard 3DLevelScanner II.

Materials	
Housing	Painted aluminum die casting
Conduit	PA6
Ambient conditions	
Ambient, storage and transport temperature	-40...85°C (-40...+185°F)
Relative humidity	20...85%
Sealing	
Protection	IP67
CE	
EMC - Emission	EN 61326:1997 (class B)
EMC - Susceptibility	IEC / EN 61326:1997 + A1:1998 + A2:2001 + A3:2003
NSR (73/23/EWG)	EN 61010-1:2001

# Head Body Separation Kit

## Technical Data Sheet



Changing the market  
from level to volume

### Head Body Separation Kit with 3DLevelScanner II

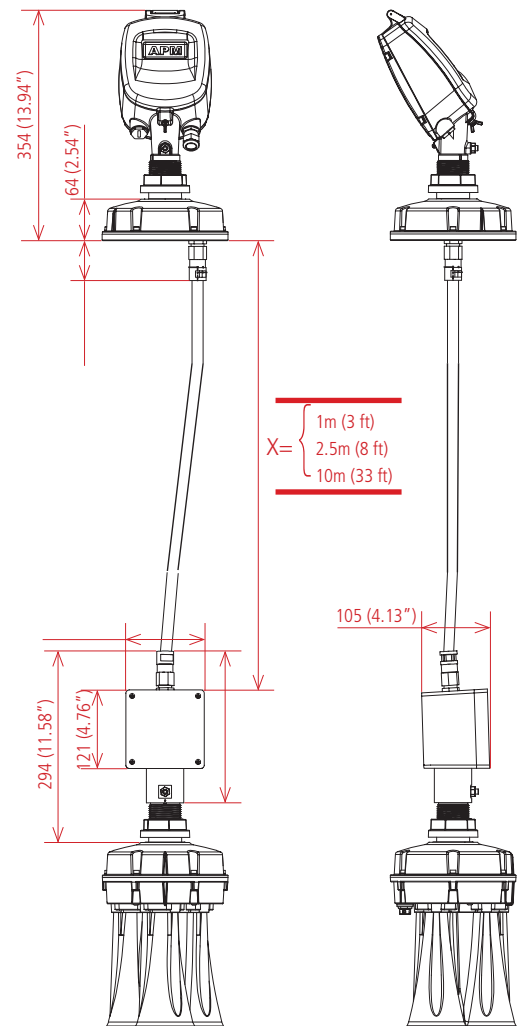

Dimensions in mm (inch)

# Head Body Separation Kit

## Mounting Instructions

**A** Place the flange onto the neck tube. Ensure that the O-ring on the neck tube remains in place for sealing.

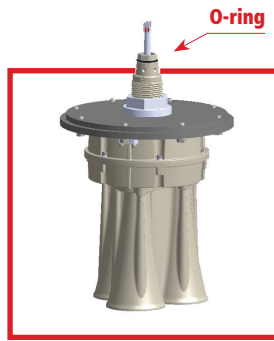

**B** Remove the antenna connection box cover.

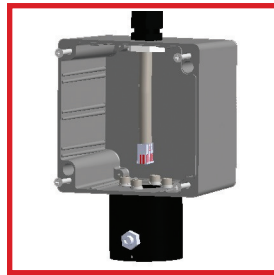

**C** Mount the box onto the scanner's neck tube. Note: the pin on the connection box must align with the groove on the neck.

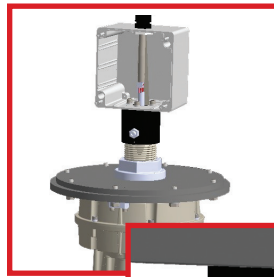

Align the pin with the groove on the neck

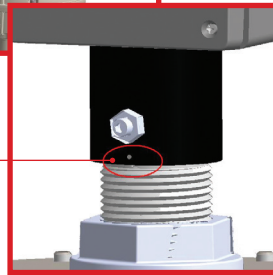

**D**

Fasten

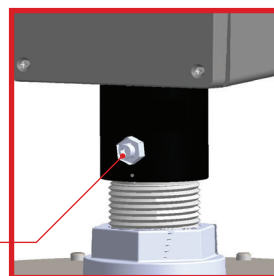

**E** Connect the scanner cable to the antenna connection box cable. Close the box cover.

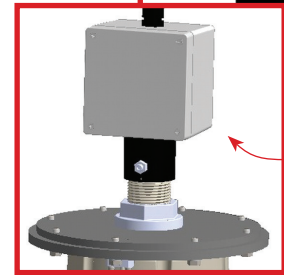
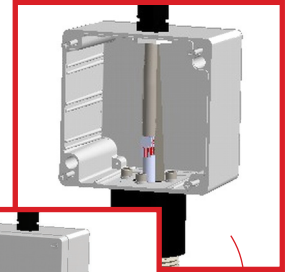

**F** The Head Mounting part is supplied with the extension cable wired.

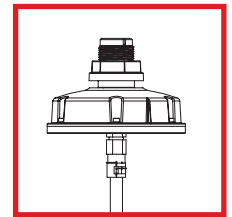

**G** Mount the Head Mounting part on a support or flange with 52mm hole for the neck. To avoid unnecessary damage to the cable, if the conduit is to be bent during installation, make sure that the radius of the bend is greater than 2.75" (70mm).

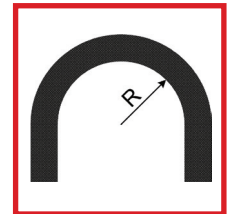

**H** Route the Conduit from the Head mounting part to the body in a secured path to avoid accidental damage.

**I** Continue the installation according to the instructions in the "APM Quick Installation Guide" manual.



### APM Automation Solutions Ltd.

ATIDIM High-Tech Industrial Park  
Building 2 P.O. Box 58171  
Tel Aviv 61580, Israel  
Tel: +972 3 6488891  
Fax: +972 3 6488892  
info@apm-solutions.com  
www.apm-solutions.com