



# The Leader In Dry Bulk Level Measurement





## ORIGINAL, GENUINE

Established in 1936, Bindicator® has built level switches to solve the toughest bulk material handling challenges. We have more history and experience with dry bulk level measurement than any other company. There are over 1,000,000 Bindicator® level instruments at work every day around the world.

## PRODUCTS THAT ARE BUILT TO LAST

Bindicator® has always emphasized heavy-duty construction. Our designs are rugged. Bindicator® products are built to withstand rough treatment and extreme environmental conditions. Our products are built in an ISO-9001 factory and are endorsed by leading approval agencies including Underwriters Laboratories, CSA, CENELEC, ATEX, and many others.

## APPLICATION EXPERTISE YOU CAN RELY ON

Bindicator® is well known for our applications engineering expertise and after sales service. Our applications engineers and service technicians understand the various types of materials and the vessels they are stored and processed in. These application experts take genuine responsibility in ensuring the right product is applied to the right application.

## DEDICATED TO YOUR SUCCESS

Bindicator® stands behind its products. We have been a leader in the industry for decades because we deliver value.

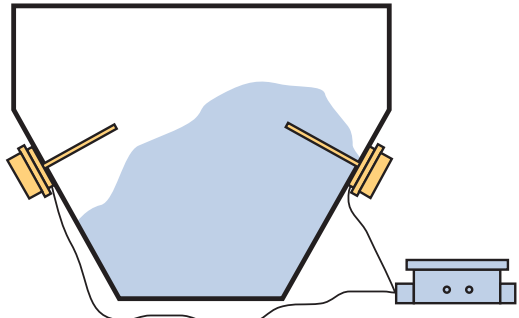
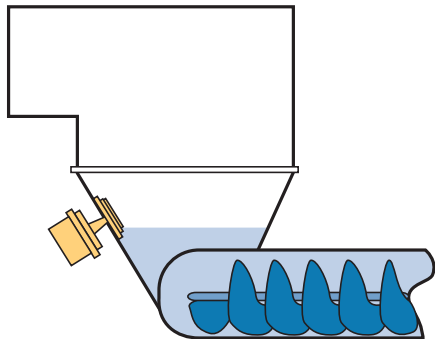

# Bindicator® has a product that best fits your application

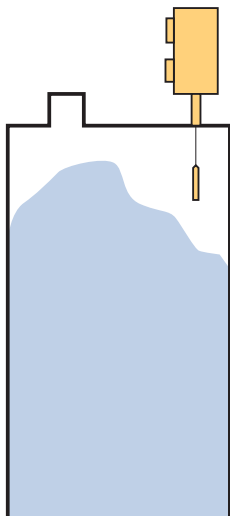
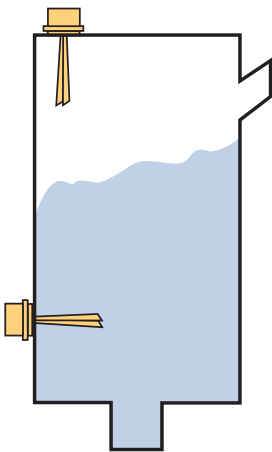
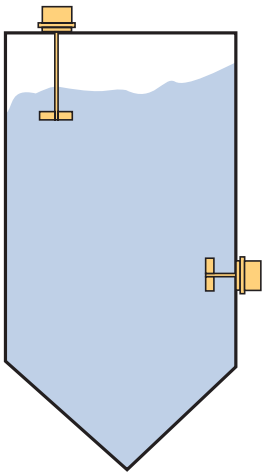

	POINT LEVEL						CONTINUOUS LEVEL						
	VRF-2000 Series	VRF-1000 Series	Pulse Point™ [P-100	Pulse Point™ [P-200 (remote)	Roto-Bin-Dicator®	Bin-Dicator® Diaphragm	Liquid Level Bindicator®	Yo-Yo® (GP-4 & Mark-4)	Phase Tracker™	***MS-2000™ Ultrasonic Series	***Cap-Level® II/IIA	***Level Data™	***Mach One™
<b>Material</b>													
Powder	•	•	•	•	•	•	•	•	•	•	•	•	•
Granular	•	•	•	•	•	•	•	•	•	•	•	•	•
Slurry	•	•						•	•	•	•	•	•
Liquid	•	•					•	•	•	•	•	•	•
<b>Material Density</b>													
Very Low <15 PCF			•	•			n/a						
Low > 15 PCF	•		•	•			n/a	•	•	•			
High > 40 PCF	•	•	•	•	•	•	n/a	•	•	•			
<b>Material Moisture</b>													
Low	•	•	•	•	•	•	n/a	•	•	•	•	n/a	n/a
High	•	•	•	•	•	•	n/a	•	•	•	•	n/a	n/a
<b>Temperature</b>													
High [over 200° F (93° C) to 1000° F (538° C)]	*	*		•		•		**			•		
<b>Pressure</b>													
Atmospheric	•	•	•	•	•	•	•	•	•	•	•	•	•
< 10 Psi	•	•	•	•	•	•	•	•	•	•	•	•	•
10-50 Psi	•	•	•	•				•	•	•			
50-100 Psi	•	•							•	•			
<b>Vibration</b>													
Low	•	•	•	•	•	•	•	•	•	•	•	•	•
High	*	*						•		•			
<b>Material Coating</b>													
Minimal	•	•			•	•	•	•	•	•	•	•	•
Heavy Build Up	•	•			•	•	•	•	•				•
<b>Corrosives</b>													
Low	•	•	•	•	•	•	•	•	•	•	•	•	•
High	•	•	•	•						•	•		•
<b>Installation</b>													
Vert. (top mount)	•	•	•	•	•	•	•	•	•	•	•	•	•
Horiz. (side mount)	•	•	•	•	•	•					•		
Non-Contact										•			•
<b>Atmosphere</b>													
Dust	•	•	•	•	•	•	n/a	•	•	•	•	n/a	n/a
Steamy			•	•			•	•			•	•	
Non-Air Vapor	•	•	•	•	•	•	•	•	•		•	•	

\*VRF remote and cable series available. Consult factory for details.

\*\*Mark-4 only.

\*\*\*See specification sheet for more information.

# Roto-Bin-Dicator®

The Roto-Bin-Dicator® is the most universal of all level sensing technologies and is the most popular level switch used in dry bulk materials. The Roto-Bin-Dicator® is a rotating paddle type, bulk material level sensor offered with a wide variety of paddle options for unequaled application versatility. It is easy to install and requires no special tools or calibration.

## FEATURES AND BENEFITS

- **Simple Mechanical Mechanism**

No calibration required

- **Wide Variety of Paddle Options**

Unequaled application versatility

- **Mount in Any Orientation**

Gives user the option of applying sensor for high, intermediate, or low level control

- **1 or 2 SPDT Switches**

Gives user the capability to turn off or on up to two auxiliary devices

- **Explosion Proof & Stainless Steel Enclosures Available**

Provides more options for a wide range of applications

- **Special Motor Design**

Allows power to be applied all the time, producing heat and eliminating condensation inside the enclosure

- **Captive Screws**

No lost screws



## How the Roto-Bin-Dicator® Works

- 1 The Roto-Bin-Dicator® incorporates a low torque, slow speed synchronous motor [A]. The motor rotates a paddle [B] which is extended into the bin.
- 2 As the material builds up to the Roto-Bin-Dicator®, the paddle is stopped, which in turn stalls the motor. As the motor stalls, it actuates switches [C].
- 3 The torque of the motor, while stalled, serves to keep the switches actuated while the paddle rotation is stopped by the presence of bulk material.
- 4 The switches in the Roto-Bin-Dicator® serve to energize audible and visual signal systems and/or stop and start machinery such as conveyors, elevators, feeders, etc.

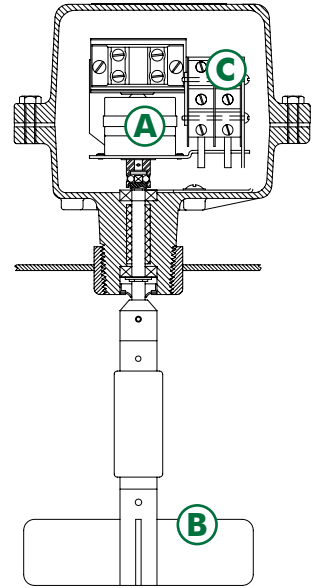

## Typical Applications

Roto-Bin-Dicator® level switches can be used to eliminate bin overflow, empty bins, clogged conveyors, or choked elevators. The Roto-Bin-Dicator® can be used on practically any bulk material such as:

- coal
- chemicals
- feed
- aggregates
- grain
- food products
- powders
- cement

### Original



- Low level fail-safe protection
- Low torque motor
- Few parts

### Super-Safe-Plus



- High or low level fail-safe operation
- Lights on enclosure cover
- External function test

### Mini



- Compact size
- Adjustable sensitivity
- External LED

# Pulse Point™

The Pulse Point™ is an electronic vibratory level control especially effective in lightweight powders and granular solids. Because the Pulse Point™ senses material using a mechanical principle, the dielectric constant of the material is irrelevant.

## FEATURES AND BENEFITS

- **Simple Mechanical Mechanism**  
No calibration required
- **1 1/4" or 1 1/2" NPT Top or Side Mount**  
Multiple mounting options to choose from
- **Dual-Tine, Self-Cleaning Action**  
Won't "rat hole" like single-tine vibratory units
- **Field Selectable Fail-Safe Operation**  
Single model will work in low or high level
- **DPDT (LP-100) or SPDT (LP-30) Switches**  
Gives user the capability to turn off or on up to two auxiliary devices
- **Adjustable Time Delay**  
Switch activation can be delayed to user defined time settings (0-25 seconds)
- **Ability to Sense Lightweight Materials**  
Densities as low as 2 lbs/ft<sup>3</sup> (32 kg/m<sup>3</sup>)
- **Captive Screws**  
No lost screws



## How the Pulse Point™ Works

- 1 Piezoelectric transmit and receive crystals **[A]** in the base of the fork create and sense movement of the tines **[B]**. The electronics **[C]** and transmit crystal drive the oscillation, and when in air, the tines vibrate at about 100 Hz.
- 2 When material contacts the fork tip, the oscillation diminishes because the fork is now dampened by material contact.
- 3 The receive crystal **[A]** senses this difference and changes the state of the output relay.

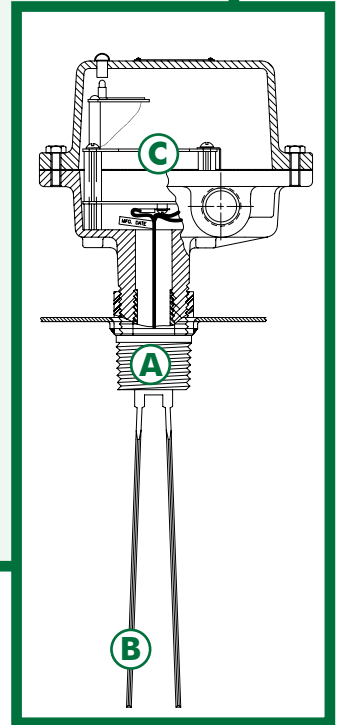

The Pulse Point™ products are designed for use in dry materials that are heavily aerated such as:

- plastics
- reground plastic film
- tobacco
- cement
- sawdust
- carbon black
- paper shavings
- sand
- insulation
- light fibers
- dry cereals
- clay

## Typical Applications

### LP-100



- External LED operation and alarm lights
- DPDT output relay
- External function test using magnetic fob
- No calibration required
- Liquid/solid interface

### LP-30



- Simple design
- SPDT output relay
- Dual conduit housing allows for separation of input wiring and alarm wiring

### Remote Version



- Remote version of LP-100
- High temperature applications up to 248° F (120° C)
- External function test using magnetic fob
- No calibration required
- Liquid/solid interface

# VRF™ Series

Surpassing the sensitivity of RF technology, VRF™ provides superior level detection. The VRF™ series uses Variable Radio Frequency to detect the presence or absence of material in a vessel by compensating for the load of the probe, as well as the load induced by vessel environment, and automatically determining the optimal operating frequency for the greatest sensitivity and stability. At initial start-up the sensor detects the characteristics of air (no load) and calibrates to it. If installed in material, when the load is reduced (material leaves probe), the VRF™ senses this change and automatically recalibrates to its new condition without the need of an operator or technician.

Bindicator® manufactures an array of VRF™ probes, each tailored for specific applications. When combined with our large selection of probes, we have a VRF™ sensor for virtually every application. Please consult one of our representatives or call the factory for application assistance.

## FEATURES AND BENEFITS

- **Opti-Sense™**

Uses variable radio frequency (VRF™) technology to determine the **optimal** operating frequency for greatest sensitivity and stability

- **Wide Variety of Probe Options**

Unequaled application versatility

- **Test In Place**

Test by using a magnetic fob without removing the cover (VRF-2000)

- **Pro-Guard™**

Probe design ignores material build-up on probe

- **EZ-Cal® II**

No initial manual calibration required

- **Explosion Proof & Stainless Steel Enclosures Available**

Provides more options for a wide range of applications

- **Calibration Status and Alarm Lights**

Green LED indicates calibration status; red LED indicates alarm status (VRF-2000)

- **Captive Screws**

No lost screws



# How the VRF™ Series

- 1 The VRF™ Series works on the radio frequency/capacitance principle. The sensing electronics have been designed to detect the difference between the electrical characteristics of air (no material) and the material being detected.
- 2 A microprocessor digitally analyzes voltage and current values to characterize the complex impedance seen by the probe. The digital signal processor continuously analyzes the conductance and susceptance of the probe circuit and calculates when to alarm the unit.
- 3 EZ-Cal® II automatically calibrates the unit to air. If installed in material, as material discharges and leaves the probe, the VRF™ will sense the lower load (capacitance) and recalibrate.

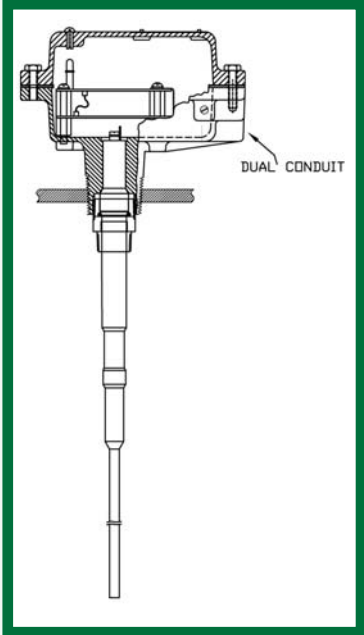

## Typical Applications

The VRF™ Series is well suited for severe applications including high temperatures, high pressures, and corrosives. Specific applications include, but are not limited to:

- coal
- flour
- grains
- plastics
- sawdust
- flyash
- sugar
- pharmaceuticals
- asphalts
- concrete

### VRF-2000



- EZ-Cal® II
- External CAL and alarm lights
- Calibration indication output relay
- External test in place
- Dual conduit housing

### VRF-1000



- EZ-Cal® II
- Dual conduit housing allows for separation of input wiring and alarm wiring

### Remote Version



- EZ-Cal® II
- For high temperature applications up to 1000° F
- For high vibration applications
- Dual conduit housing

VRF-2000 shown

The original electromechanical point level switch, Bin-Dicator® diaphragm-type level controls were the first to enjoy general usage in the industry. Bin-Dicator® controls eliminate bin overflow, empty bins, clogged conveyors, choked elevators and resulting damage and waste.

## How the Bin-Dicator® Works

The Bin-Dicator® control is a pressure actuated switch for use with free flowing bulk materials at atmospheric pressures. Actuation of the switch is the result of pressure exerted by the bulk material against the diaphragm assembly. De-actuation or switch release is a result of the bulk material clearing away from the diaphragm.

## FEATURES AND BENEFITS

### • Simple and Rugged Construction

Can be mounted outside the bin for lower installation costs

### • Simple Operating Mechanism

Makes entire unit readily accessible for inspection, resulting in lower maintenance costs

### • Many Variations Available

For use in a wide range of dry materials and conditions of temperature, corrosion and moisture

### • SPDT Switch

No need to power electronics

- chemicals
- mining
- plastics
- ceramics

## Typical Applications

### Model "A"

- 10 ¼" diameter
- Explosion proof model available
- 7 diaphragm material options
- Heavy duty

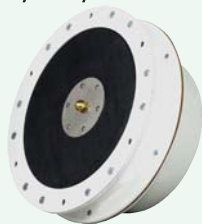

### Auto-Bin-Dicator®

- 8" diameter
- Cast aluminum housing
- Neoprene or S.S. diaphragm material
- Medium duty



### Bantam

- 5 ¾" diameter
- 2 diaphragm material options
- Light duty



# Bin-Flo®

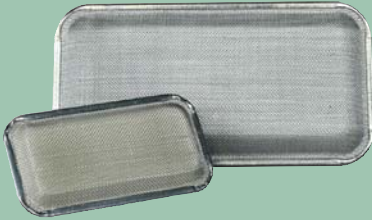

- Can be installed from inside or outside the bin, only one drilled hole needed per pad
- Integral orifice
- Non-clogging diffuser

The Bin-Flo® aerator is a simple and efficient means of introducing low pressure air into any dry finely ground material. The air is equally distributed in controlled quantities to give the material the ability to flow by gravity from bins, hoppers or chutes. Bin-Flo® aerators incorporate non-clogging diffusers, an integral orifice and construction features which assure long, maintenance-free life.

- detergents
- chemicals
- clay
- feed
- flour
- sawdust

## Typical Applications

# Flo-Guard®

Indicator's Flo-Guard® is a stable and reliable Broken Bag Detector and a Flow/No-Flow Switch for dry, powdered, and granular materials. The Flo-Guard® uses a floating alarm point reference and a digital triboelectric microcontroller to eliminate instability common in other flow switches.

- grains
- plastics
- sawdust
- food
- aggregates

## Typical Applications



- Easy set-up
- Fob function test
- External alarm and power LEDs
- Field selectable fail-safe operation
- Remote version available

The GP-4 and Mark-4 Yo-Yo® sensors are designed to provide accurate and reliable inventory management information for tanks and silos.

The GP-4 is housed in a NEMA 4 enclosure. The Mark-4 Yo-Yo® sensor is housed in a NEMA 4/7/9 enclosure. The Bindicator remote display/programmer can request readings, monitor up to 99 GP-4 and Mark-4 sensors, and program silo parameters. The display/programmer allows a user to configure a single sensor or a whole system. An adjustable autotimer allows the user to set automatic measurement cycles ranging from 2 minutes to 1 week. While in operating mode, the display will show the sensor address, sensor name, measurement in the specified units, percentage, display mode and the status of the current device.

In addition, both the GP-4 and Mark-4 sensors can be interfaced to a PC using *i-LEVEL™* software. *i-LEVEL™* provides all the capabilities of the display/programmer plus the added ability to trend historical data.

## FEATURES AND BENEFITS

### · Silos up to 100 ft (30.5m)

Large range of silo heights can be accommodated

### · 1cm (0.39 inches) Resolution

Accurate readings

### · Isolated 4-20mA Output with Adjustable Span (Reversible)

No loop isolator is required when connecting to a PLC or DCS

### · RS-485 Communication

MODBUS protocol

### · Remote Display Programmer with Keypad

- 4-line x 20-character backlit LCD display
- Programmable sensor names and ranges
- Enable/Disable network addresses



Web-based *i-LEVEL™* Inventory Management Software Available (See page 15)

## How the Yo-Yo® Works

- 1 The Bindicator® Yo-Yo® is an electromechanical device consisting of a sensor mounted on the top of a vessel.
- 2 The sensor contains a weight **[A]** suspended by a cable **[B]** with motion provided by a motor drive **[C]** and associated electronics.
- 3 The measurement cycle is initiated either on demand or on a timed interval and causes the sensor to lower the weight to the material level. As the weight is being lowered, the length of cable dispensed is measured in 1 cm (0.39") increments.
- 4 When the weight reaches the material level, the unit reverses and the weight is drawn into the stored position in the sensor. The distance measurement can then be transmitted via 4-20mA, or RS-485 MODBUS to the display/programmer or to a PC (i-LEVEL™).

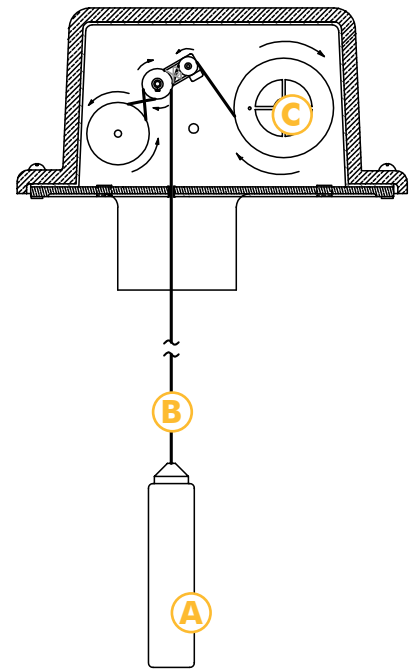

## Typical Applications

- aggregates
- granules
- plastic resin
- pellets
- powders
- liquid/solid interfaces

### GP-4

- NEMA 4
- Surface mount components



### Mark-4

- NEMA 4/7/9
- Surface mount components
- Hazardous area approved



### Remote Display

- 4-line x 20 character backlit LCD display
- Monitors and requests readings of up to 99 vessels
- Programs vessel parameters and enables/disables sensors



# Phase Tracker™

Bindicator's patented Phase Tracker™ is designed to solve the most challenging continuous level applications. It has no moving parts and uses a sophisticated electronic signal to accurately measure even the most difficult materials in the most demanding environments.

Phase Tracker™ is ideal for the level measurement of bulk solids. It can accurately and reliably measure the level of bulk solids and powders during the fill cycle, regardless of dust or material variations in density or moisture. It is effective in non-air vapor, fumes, abrasives and corrosives, as well as corrugated bins and tall, narrow silos.

Phase Tracker™ sensing technology is independent of two of the most common problems that affect continuous level instrumentation: variation in the environment and changes in the product being measured. Phase Tracker™ can be applied throughout the processing, manufacturing, and material handling industries to solve tough measurement applications.

## FEATURES AND BENEFITS

- **Unique, Patented Principle of Level Measurement**

- Much lower frequency than radar, therefore less affected by noise

- **Designed for Difficult Applications**

- Approved for hazardous areas and signal not affected by changes in temperature, particle size, density or moisture content

- Works well in:

- Low dielectrics
    - Dust/vapor environments
    - Tall/narrow silos
    - Grain elevators/multi-tank installations

- **Measures a 6" Radius Around Sensor Cable**

- Not affected by corrugated side walls or cross members and inherently immune to product coating

- **Setup Without Emptying Tank**

- No start-up downtime

- **Does Not Use Timing to Determine Length**

- Higher accuracy at longer lengths

- **Expandable Controller**

- Up to 24 tanks per control unit

- **Multiple Ways to Program**

- All functions programmed through keypad, PC or via modem (with *i-LEVEL™* software)



# i-LEVEL™ Software



i-LEVEL™ provides easy windows interface to view numerical and graphical data generated by Phase Tracker™ and GP-4/Mark-4 Yo-Yo® level systems. Data is updated in real-time as it is received or when requested from a server. With historical trending, i-LEVEL™ provides operators and managers with up-to-the-minute level and inventory information.

## FEATURES AND BENEFITS

### • Web Based Software

Software required only at one PC/server, and accessible from anywhere, anytime

### • Easy Access

Multiple users can access a server simultaneously using standard browsers

### • Data Security

Password protected for both intranet and internet access

## Sample Screen Shots

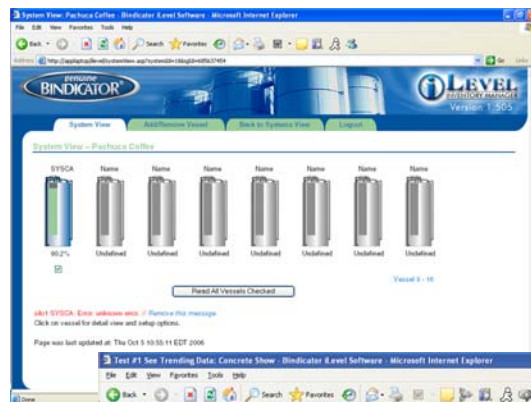

System View

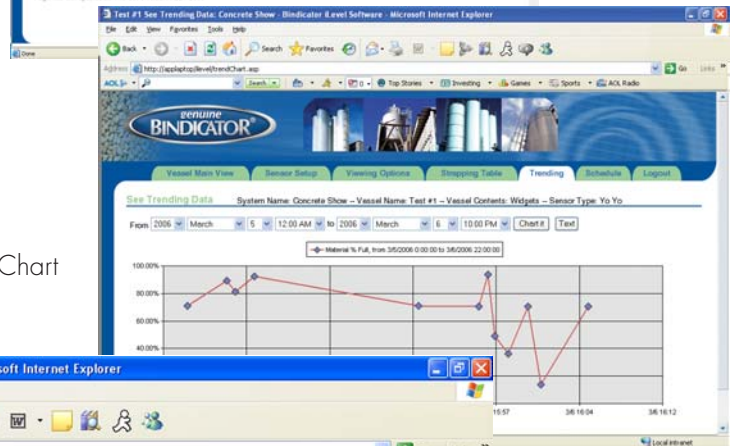

Trending Chart

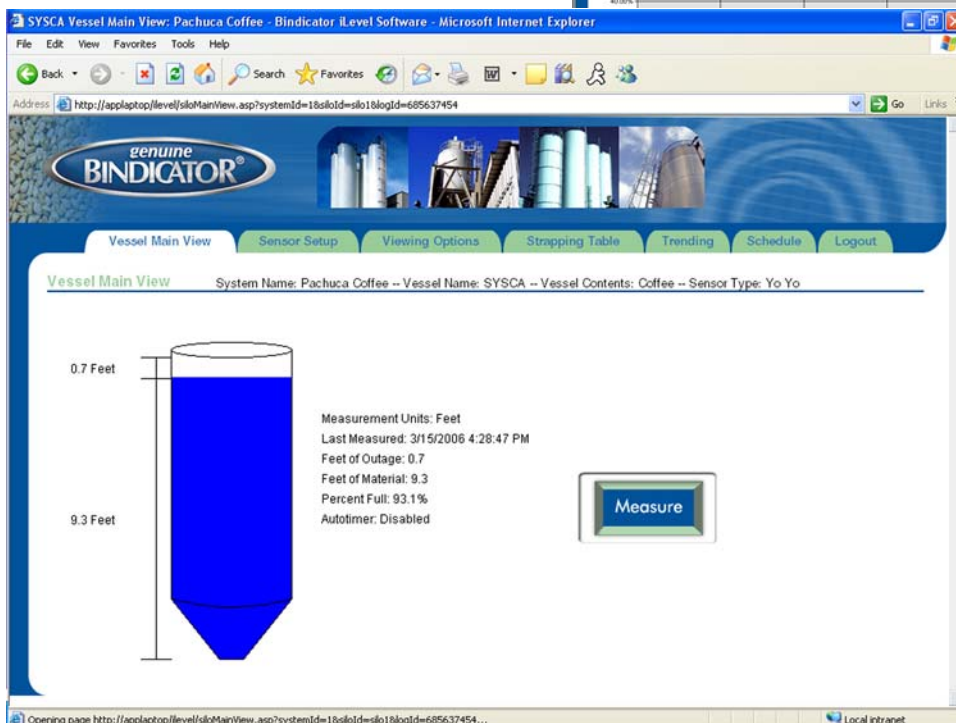

Vessel Main View

## Bindicator® Representatives

Bindicator® has an established network of trained representatives across North America that stock Bindicator® level instruments. Visit [www.bindicator.com](http://www.bindicator.com) or telephone our Customer Care department at (800) 778-9242 to be directed to the Bindicator® representative in your area.



**150 Venture Boulevard • Spartanburg, SC 29306**

**Tel: (800) 778-9242 • (864) 574-8060**

**Fax: (864) 574-8063**

**E-mail: [sales@bindicator.com](mailto:sales@bindicator.com)**

**[www.bindicator.com](http://www.bindicator.com)**

2006 All rights reserved.  
All data subject to change without notice.

LXX090737 Rev. E